

SONO AH SONO RAO

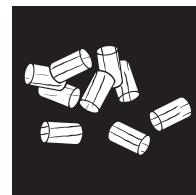

Operating manual



TABLE OF CONTENTS

Explanations to symbols.....	3
1. IMPORTANT INFORMATION	5
Packaging.....	5
General warning and safety information.....	5
Electrical connection.....	5
First heating.....	5
The correct chimney connection.....	6
Multiple and mixed occupancy.....	6
Room air-independent operation.....	6
Room air-dependent operation.....	6
Convection air conduction.....	6
2. INSTALLING THE STOVE	7
Connection to the chimney.....	7
Connecting to a steel chimney.....	7
Combustion air.....	7
Feeding in external combustion air.....	7
3. FIRE PROTECTION	8
Minimum distances.....	8
Radiation range.....	9
Floor protection.....	9
4. TECHNOLOGY AND SAFETY FUNCTIONS	10
Operating comfort.....	10
Top efficiency - lowest emissions.....	10
DAR - Dynamic Air Regulation.....	10
Pressure monitoring.....	10
Low-temperature shutdown.....	10
Electrical excess current protection.....	10
Automatic cleaning cycle.....	10
Component monitoring.....	10
Auger motor monitoring.....	10
Power failure (during heating).....	10
Power failure (during the initial stage).....	10
5. COMFORT OPTIONS	11
Room sensor, Radio room sensor.....	11
Interface for various options.....	11
External request.....	11
Serial interface.....	11
USB connection.....	11
External room thermostat.....	11
External connection cable bridge.....	11
Option RIKA FIRENET 2nd Generation.....	11
RIKA VOICE.....	11
6. BRIEF INFORMATION ON FUEL - PELLETS	12
What are pellets?.....	12
Wood pellet specification according to ENplus – A1.....	12
Pellet container refilling during operation.....	12
Pellet storage.....	12
Time-burning fireplace (INT).....	12
Amount of fuel.....	12

7. INSTRUCTIONS FOR COMMISSIONING PROTOCOL	13
Operator instruction	13
8. ASSEMBLY / DISASSEMBLY PANELS	14
9. MAINTENANCE	15
Open the combustion chamber door	15
Clean burn pot	15
Cleaning the flame temperature sensor	15
Empty the ash drawer	15
Clean door glass	15
Clean painted surfaces	15
10. CLEANING	16
Clean convection air openings	16
Clean combustion air intake	16
Clean the pellet container	16
Clean the flue pipes	16
Check bearings	16
Check seals	16
Cleaning the flue gas channels and flue gas collecting duct	16
11. PROBLEMS - POSSIBLE SOLUTIONS	18
Problem 1	18
Problem 2	18
Problem 3	18
12. TECHNICAL DATA	20
Dimensions, weight and connection	24
Dimensions, weight and connection	25
Technical Details	26
Spare parts overview Exploded view	27
Spare part overview article numbers	31
13. GUARANTEE CONDITIONS	34
14. WARRANTY CONDITIONS	34
15. DISPOSAL INFORMATION	35
Information on the individual components of the device	35
Extract from the waste code of the European Waste List Regulation	35
Electronic Waste	35
16. COMPLIANCE WITH EU REGULATIONS	35

Explanations to symbols



...Important note



...Manually



...Hexalobular T25



...Useful tip



...Hex #13



...complies with EU regulations



...Read and follow the operating instructions



...do not dispose of in household waste



A STOVE IS ALWAYS MORE THAN „JUST“ A SOURCE OF HEAT.

Dear customer,

We would like to thank you for purchasing our high-quality stove. With this quality product, we not only want to bring warmth into your home, but also create cosiness and comfort.

We are proud to be able to offer you a product that is not only functional, but also impresses with its attractive design. We attach great importance to quality and sustainability and are convinced that you will enjoy your new stove for a long time.

To ensure the long-term performance and efficiency of your stove, it is important to carry out regular cleaning and maintenance work. Here are some important points to bear in mind:

- 1. clean the inside of the oven regularly to remove deposits and dirt. You will find detailed information on this under „CLEANING & MAINTENANCE“.**
- 2. have the oven serviced regularly by a specialist to ensure that all components are working properly and show no signs of wear.**
- 3. please also observe the recommended safety measures to avoid accidents and damage.**

By carrying out these simple care and maintenance measures regularly, you can ensure that your stove functions optimally and that you can enjoy it for a long time.

We wish you a pleasant „oven time“ and thank you for your trust and support.

Yours sincerely

Karl Stefan Riener

Karl Philipp Riener

Stefan Riener

1. IMPORTANT INFORMATION

Packaging

Your first impression is important to us!

The packaging of your new stove provides excellent protection against damage. However damage to the stove and accessories may still occur during transport.

Note

Therefore please check your stove on receipt for damage and completeness! Report any deficiencies to your dealer immediately! Pay particular attention during unpacking that the stone panels remain intact. Scratches to the material can easily occur. Stone panels are excluded from the warranty

The packaging of your new stove is environmentally neutral to a great extent.

Tip

The wood used in the packaging has not been surface treated and may therefore be burnt in your stove. The cardboard and film (PE) can be disposed of via the municipal waste collection for recycling.

General warning and safety information

Observance of the introductory general warning information is imperative.

- Read the entire manual thoroughly before installing and putting the stove into service.
- The owner of the small firing installation or the person authorised to dispose of the small firing installation must keep the technical documentation and present it to the authorities or the chimney sweep on request.
- Observe the national and European standards and local regulations that apply to the installation and operation of the fireplace!
- RIKA stoves should only be installed in rooms with normal humidity (dry areas according to VDE 0100 Part 200). The furnaces are not splash water protected and may not be installed in wet areas. The minimum size of the installation space is 40 m³.
- Before installing the stove, make sure that the load-bearing capacity of the substructure can withstand the weight of the stove
- Only approved transport equipment with sufficient load carrying capacity may be used with your heating appliance.
- Your heating appliance is not suitable for use as a ladder or stationary scaffolding.
- Under no circumstances may the stove be operated with defective door seals. The seals must be replaced with original RIKA seals by a specialised company.
- The burning of fuel releases heat energy that lead to extensive heating of the stove surfaces, doors, door and operating handles, glass, flue pipes and possibly the front wall. Refrain from touching these parts without appropriate protective clothing or equipment e.g. heat-resistant gloves or means of operation (operating handle).
- Make your children aware of this particular danger and keep them away from the stove during heating.
- Only burn approved heating materials.
- The combustion or introduction of highly flammable or explosive materials (petrol, petrol-type lamp oils, paraffin, barbecue coal lighter, ethyl alcohol or similar liquids), such as empty spray cans etc. in the combustion chamber and storing them near the stove is strictly prohibited due to the danger of explosion.
- No light or inflammable clothing is to be worn when post-heating.
- Make sure that no embers fall out of the combustion chamber onto combustible material.
- Placing non-heat resistant objects on the stove or near it is prohibited.

- Do not place clothing on the stove to dry.
- Laundry racks etc. must be placed at a sufficient distance to the stove – ACUTE DANGER OF FIRE!
- When your stove is burning, the use of highly inflammable and explosive materials in the same or adjacent rooms is prohibited.
- If the stove is heated in continuous operation, the cleaning intervals are shorter. Increased wear, especially of the thermally stressed parts, is the result. Please therefore strictly follow the requirements for cleaning and maintenance!

Note

Waste and liquids may not be burnt in the stove!

Note

To prevent your stove from overheating of the internal components, do never cover the convection fins!

Note

CAUTION when filling the pellet container. The opening of the pellet container is sufficiently dimensioned to ensure easy filling. Take great care that no pellets drop to the convection fins and the hot stove body. This can cause a lot of smoke.

Tip

Therefore we recommend refilling the pellet container at a cold stove.

Note

Your stove will expand and contract during the heating and cooling phase. This can sometimes lead to slight bending or cracking noises. This is normal and is no reason for a complaint.

Note

No changes may be made to the fireplace. This will also invalidate the guarantee and warranty.

Electrical connection

The stove is supplied with an approx. 2m long connecting cable with a Euro-plug. This cable is to be connected to a 230Volt/50Hz socket. The average electrical power consumption is about 20 Watt in heating operation. And approx. 150 Watt during automatic ignition. The connection cable must be laid so that there is no contact to any sharp edges or hot surfaces of the stove.

Danger to life!

Operation with a damaged connection cable is not permitted! If the connection cable is damaged, it must be replaced immediately by a qualified specialist company to avoid further danger.

Note

No liability is accepted for damage to the appliance caused by improper connection and use and the warranty is void.

First heating

The stove body, just as various steel parts, cast iron parts and the flue pipes are painted with a heat resistant paint. During the first heating the paint dries out completely. This may cause a slight smell. Touching or cleaning the painted surfaces during the curing should be avoided. The hardening of the paint is finished after the first heating with high power.

The correct chimney connection

To select the connection and to ensure a correct connection between the stove and the chimney (flue), please read the section on INSTALLING THE STOVE or ask your local master chimney sweep.

- Flue pipes pose a particular source of hazard regarding gas leaks and fire. Get the advice of an authorised specialist company for the layout and assembly.
- Please observe the corresponding installation guidelines for walls panelled with wood when connecting your flue pipes to the stove.
- Observe the formation of flue gas (atmospheric inversion) and draughts when the weather is unfavourable.
- Instead of too little combustion air can lead to smoke in the rooms or to flue gas leaks. Hazardous deposits in the stove and chimney may also occur.
- If flue gas escapes, let the fire burn out and check whether all the air inlet openings are free and the flue gas pipes and the stove pipe are clean. If in doubt notify the master chimney sweep since draught malfunctions may be connected to your chimney.
- The combustion chamber door is to be kept closed when the stove is not in operation.
- Fouling of the chimney i.e. deposits of highly inflammable materials such as soot and tar and subsequently fire in the chimney may occur if the chimney is miscalculated and dimensioned wrong and if wet wood is used.
- If fire in the chimney occurs, disconnect the mains plug of the stove. Phone the fire brigade and get yourself and other residents out of harm's

Multiple and mixed occupancy

- Your stove is suitable for multiple and mixed use and may only be operated with the combustion chamber door closed.
- A chimney calculation in accordance with EN13384-2 is required.
- Mixed use only in conjunction with BROKO safety device in accordance with DiBt approval Z-43.13-485.
- Please note the different national regulations.

Room air-independent operation

Your stove corresponds to type CC and can therefore also be operated as a room air-independent pellet stove.

Provided that the required combustion air is supplied from outside via sealed pipes, the stove may also be installed in utilisation units that are permanently airtight in accordance with the state of the art, as well as in utilisation units that are equipped with mechanical ventilation or extraction systems. (See SUPPLY OF EXTERNAL COMBUSTION AIR).

The built-in differential pressure switch checks the differential pressure between the combustion chamber and the installation room required for proper operation.

If the required differential pressure is not sufficient, the stove cannot be put into operation or operation is stopped for safety reasons.

No flue gases can escape in dangerous quantities. An additional safety device is not necessary.

The stove must not be installed with ventilation systems that have a negative pressure below -15 Pa.

Note

Please always observe the applicable local regulations and rules in consultation with your local chimney sweep.



Room air-dependent operation

If the stove is installed without an external air supply, it is considered to be room air-dependent.

In this case, all the combustion air is taken from the installation room via the central air intake connection on the rear of the stove.

Therefore, make sure that there is always enough fresh air for proper combustion and that no room air extraction systems are acting on the stove.

The amount of fresh air required can be found in the technical data list. In combination with ventilation systems (e.g. controlled ventilation systems, extractor fans, etc.), it must be ensured that the stove and the ventilation system are mutually monitored and secured (e.g. via a differential pressure controller, etc.). The necessary combustion air supply of approx. 20 m³/h must be guaranteed.

Convection air conduction

only for stoves with MULTIAIR

- The amount of air and temperature of one fan is designed to heat one additional room.
- Clarify the connection situation with the responsible authority.
- The max. temperature of the convection air is 180 °C at the air outlet.
- The convection air canal should be as short as possible.
- Keep the number of deflections as small as possible.

Some models have a cover over the MULTIAIR fan ex works to prevent direct heat emission to the wall:



example

Operation without this cover or without attached convection pipes is not allowed. If you do though no warranty and no liability is accepted for damage.

Note

Please pay attention to the national and country-specific building and fire regulations when connecting the convection air pipes. Installation and assembly must be performed by a trained specialist only.



2. INSTALLING THE STOVE

Note

Assembly may only be performed by authorised specialist companies.

Note

Please observe the regional safety and building regulations. Please contact your master chimney sweep in this context.

Note

Only use heat-resistant sealing materials as well as corresponding sealing strips, heat-resistant silicon and rock wool.

Note

Also take care that the flue does not project into the free cross-section of the chimney.

Note

In case of room-air independent operation the stove pipe connections must be tightly sealed permanently. Use a heat-proof silicon to position the stove pipe on the conical supports of the flue tube nozzles and for insertion in the chimney flue lining.

Note

The stove should not be pushed on unprotected floors.

Tip

Strong corrugated cardboard, cardboard or e.g. old carpet is useful to assist assembly and as a base. The stove can also be pushed on this cardboard or carpet.

We recommend original flue pipes from RIKA for proper connection.

Connection to the chimney

- The device must be connected to a flue that is approved for solid fuels and is insensitive to moisture. The moisture insensitivity may vary if the flue calculation results in a dry operation.
- The temperature class of the flue gas system (chimney and flue pipe) must be at least class T200 soot fire resistant for pellet fireplaces in accordance with EN16510-2-6 and at least class T400 soot fire resistant for all other appliances.
- The chimney must have a diameter of min. 100 mm for pellet stoves and 130 mm -150 mm for log wood stoves depending on the diameter of the flue pipes.
- Avoid long flue pipes to the chimney. The horizontal length of the flue pipe should not exceed 1.5 metres.
- Avoid to many bends of the flue gas pipes. There should not be more than 3 bends in the exhaust pipe.
- Please use a connection with a cleaning opening.
- Connections must be made of metal and must meet the requirements of the standard (install the connections airtight).
- Before installing a chimney calculation must be made. The evidence must be performed for single occupancy to EN13384-1 and EN13384-2 for multiple occupancy.
- The maximum draft of the chimney should not exceed 15 Pa.
- The derivation of the flue gases must be guaranteed even during a temporary power outage.

Note

If connecting to multiple connection chimneys and depending on country regulations, additional safety equipment is required. Your local chimney sweep will advise you in this case.

Note

Be sure to prevent condensed water from entering via the flue connection. For combination stoves, a condensate collection pipe must be used for ceiling connection or flue pipe connection at the top. Damages caused by condensate are excluded from manufacturer's warranty.

Connecting to a steel chimney

The connection must be calculated and shown with EN13384-1 and EN13384-2.

Use only insulated (double) stainless steel tubes (flexible aluminum or steel tubes are not permitted).

An inspection door for regular inspection and cleaning must be present.

The flue pipe connection to the chimney has to be air-tight.

Combustion air

Every combustion process requires oxygen from the surrounding air. This so-called combustion air is removed from the living area in the case of individual stoves without external air connections.

This air removed must be replaced in the living space. Very tightly sealed windows and doors in modern flats may mean that too little air replaces that used. The situation also becomes problematical due to additional venting in flats (e.g. in the kitchen or WC). If you cannot feed in external combustion air, then air the room several times a day to prevent negative pressure in the room or poor combustion.

Feeding in external combustion air

only for devices which are able to run in room-air independent operation.

- Combustion air must be fed to the stove from outside via a sealed pipe for operation independent of the room air. According to EnEV, it must be possible to shut off the combustion air pipe. The open/closed setting must be clearly recognisable.
- Connect at the air intake either a pipe \varnothing 125 mm for log wood and combi stoves, or \varnothing 50 mm or \varnothing 60 mm for pellet stoves. Fix it with a hose clamp (not included!). At pellet stoves with longer intake pipes than 1 m the diameter should be increased to 100 mm. (see RIKA range).
- To ensure sufficient air intake, the intake pipe should not exceed max. 4 metres and have max. 3 bends.
- If the line leads outside it must have a windbreak.
- In extreme cold pay attention to icing on the air intake opening (check).
- It is also possible to suction in combustion air directly from another sufficiently vented room (e.g. cellar).
- The combustion air pipe must be tightly connected (adhesive or cement) permanently to the air nozzles of the stove.
- If you do not use the stove for a long time, please close the combustion air intake to prevent the stove from moisture.

Note

Please note that problems may arise due to updrafts in the case of combustion air supply from an integrated chimney ventilation shaft. If the combustion air flowing downwards is heated it may rise and thus counter the chimney with a resistance which in turn reduces the negative pressure in the combustion chamber. The chimney manufacturer is to guarantee that the resistance for the combustion air is a maximum 2 Pa even in the least favourable operating state of the chimney.

If one or more of these conditions does NOT apply, the result is poor combustion in the stove and negative pressure in the installation room.

3. FIRE PROTECTION

Minimum distances

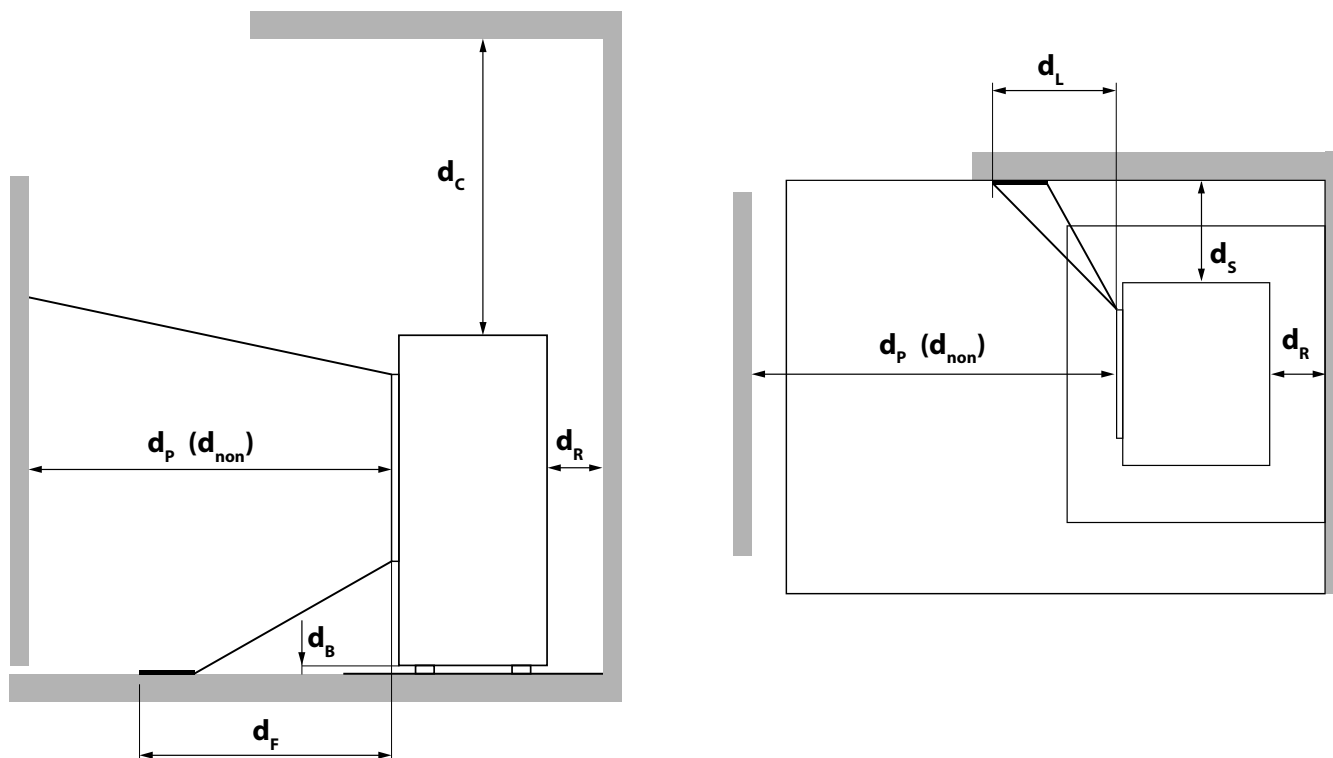

Minimum distance...

d_R	... from the back to combustible materials	[mm]	100
d_S	... from the sides to flammable materials	[mm]	100
d_C	... from the top to flammable materials in the ceiling	[mm]	500
d_P	... from the front to flammable materials	[mm]	800
d_F	... from the front to flammable materials in the lower front radiation area	[mm]	0
d_L	... from the front to flammable materials in the lateral front radiation area	[mm]	0
d_B	... below the floor (without feet) to combustible materials	[mm]	0
d_{non}	... to non-combustible walls	[mm]	400

Tip
For service and maintenance work, please keep a minimum distance of 20 cm to the side and behind the stove.



Radiation range

TO COMBUSTIBLE MATERIALS

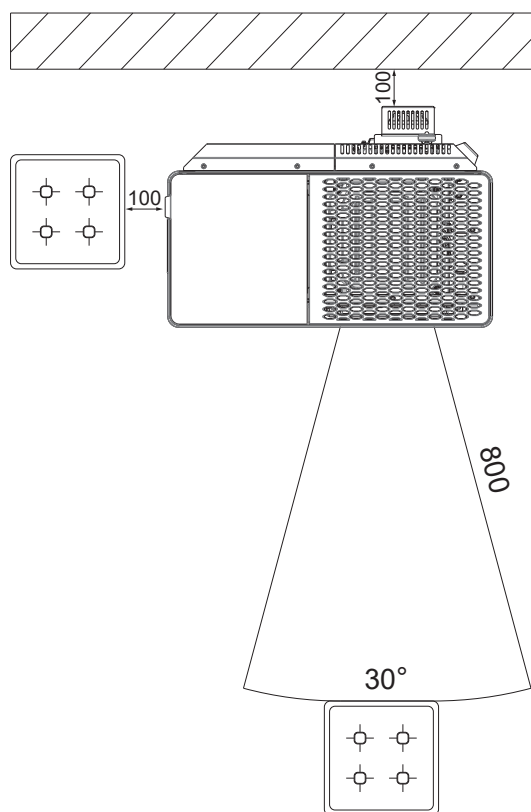

TO NON-COMBUSTIBLE MATERIALS

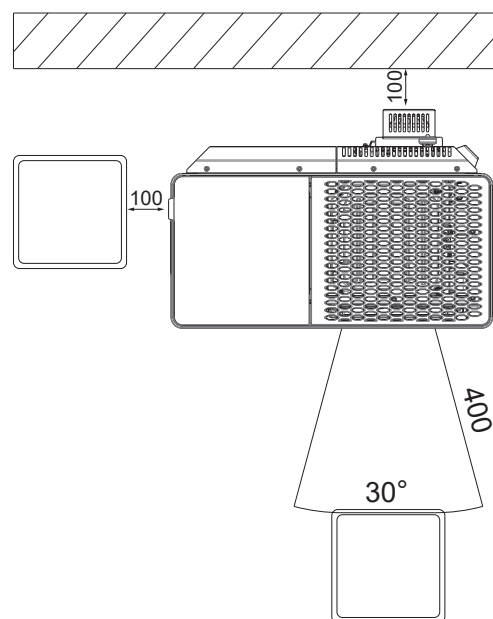

Floor protection

Combustible floors (wood, carpet, etc.) must be protected by a covering of non-combustible building materials (glass, sheet steel or ceramics). How this floor protection is to be implemented varies from country to country.

The maximum temperature at the bottom of your oven model does not exceed 60 °C above room temperature. This means that there cannot be an excessive increase in temperature in the lower area of the oven and it is not absolutely necessary to place a fireproof plate underneath. A shelf would therefore be sufficient.

Note

The country-specific regulations and ordinances must be observed!

Tip

If no state law deals with this topic, reference can be made to **ÖNORM B8311**: Fireplaces must be placed on a support made of non-combustible materials on the floor. This must protrude at least 5 cm from the side of the fireplace and at least 30 cm on the operating side in front of the combustion chamber opening.

4. TECHNOLOGY AND SAFETY FUNCTIONS

The technological advances in your new combi stove are the result of years of testing and practical experience. The practical advantages of your pellet stove are convincing:

Operating comfort

All functions can be regulated using the integrated touch display. The user-friendly interface permits extremely easy operation.

Top efficiency - lowest emissions

All processes in the stove are fully automated. The parameters

- Air control
- Temperature monitoring
- Pellet dosing

are continuously optimised. This guarantees optimum combustion. The result are low consumption and very good exhaust gas values that even undercut the legally permitted limits.

Note

Due to the automated control, you may hear flame fluttering, falling pellets and sounds from the activation of the electronic components during operation.

DAR - Dynamic Air Regulation

Only for stoves with DAR

A differential pressure sensor in the supply air system measures the air flow. The fan speed is adjusted automatically and guarantees optimum combustion.

The air pipe of an external supply air pipe can also be monitored in this way.

Pressure monitoring

The negative pressure in the combustion chamber is continuously monitored during operation. Below a defined threshold, a correct operation can not be guaranteed and the unit will switch off with the fault message „NOT ENOUGH LOW PRESSURE“ for safety reason.

Note

If the stove is used in a habitation together with a kitchen hood or a ventilation (WC) it might happen that the built-in pressure switch stops the stove. If using the hood make sure that an adequate supply of air is ensured.

Low-temperature shutdown

The unit switches off if the stove cools below a minimum temperature. This switch-off may occur if pellet ignition is delayed.

Electrical excess current protection

The stove has a main fuse (at the rear) to protect against excess current.

Automatic cleaning cycle

The speed of the flue gas fan is increased every hour for a short period to blow ash from the burn pot, increasing the operational safety. The status indicator CLEAN appears on the display.

Only for stoves with turning grids:

Every 6 hours (interval adjustable) an additionally automatic big cleaning cycle is performed. The stove stops, the automatic cleaning tilts the grid and then re-ignites the stove. The status indicator BIG CLEAN appears on the display continuously. The cleaning procedure with tilting the grid is to convey ash and clinker from the burn pot into the ash drawer.

Note

This additional function does not replace a manual cleaning as described in CLEANING and MAINTENANCE, as this is absolutely necessary to do regularly.

Note

Due to the turning grid there is a certain generation of noise during the automatic cleaning cycle (START or BIG CLEAN).

Component monitoring

All the electrical components used are continuously monitored during operation. If a component is defective or can no longer be actuated correctly, then operation is stopped and a warning or error message is issued (see MANUAL TOUCH DISPLAY).

Auger motor monitoring

Too long or wet pellets as well as pellets with too high dust content (see BRIEF INFORMATION ON FUEL PELLETS) can cause so-called "auger jammers" in the auger channel. This may also happen if the pellets accumulate in the burn pot and the backlog reaches into the chute. The auger motor reacts in both cases with an increased current consumption, which causes the error message: DISCHARGE MOTOR BLOCKED. The stove will be stopped. Please call the customer service immediately.

Power failure (during heating)

After a brief power failure, the operating functions that were set before the power failure, continues. If the power failure lasts longer, the stove goes to start phase if sufficient temperature or embers are present. If the power failure lasts too long, the stove goes into the stop phase. The flue gas fan continues to burn any pellet residues (approximately 10 minutes). Then it will restart automatically.

Power failure (during the initial stage)

After a brief power failure the boot process continues. If the power failure lasts longer, the stove is in the stop phase. The flue gas fan continues to burn any pellet residues (approximately 10 minutes). Then it will restart automatically.

5. COMFORT OPTIONS

Room sensor, Radio room sensor

This option permits control of your stove via room temperature. You can set both the room temperature and the heating times required. A room temperature selected by you is observed during the heating times.

Please see the operating instructions for the option room sensor and wireless room sensor for more detailed information.

Interface for various options

for various options

The ROOM SENSOR and the WIRELESS ROOM SENSOR are to be connected to the interface (stove rear) using the connection cable supplied.

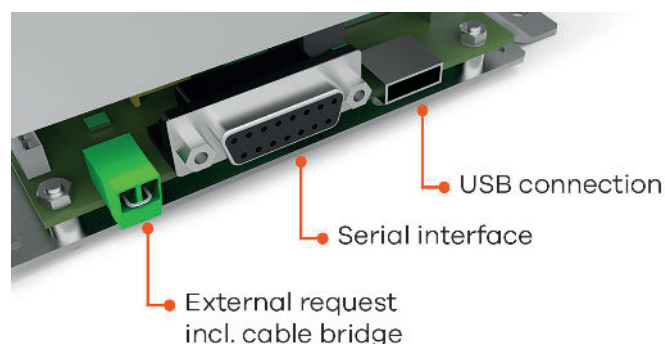

(condition as delivered)

External request

- Low-pressure controller* for multiple occupancy (e.g. BROKO - ON by default, see Settings)
- External room thermostat*, Rotary controller* (in conjunction with MULTIAIR)
- Contactor (e.g. exhaust hood)*

* remove cable bridge and connect a 2-pin cable with a section between 0.5 and 0.75mm² instead.

It will take approximately 1 minutes for your stove to shut down after receiving an external shut-down request.

Note **Operation is not possible** unless either the cable bridge, or an external request (e.g. an external room thermostat) are connected. The external request has priority over all operating modes (MANUAL / AUTOMATIC / COMFORT).

Serial interface

- RIKA room sensor/ RIKA radio room sensor (available on request)
- RIKA GSM Control (available on request)

USB connection

- RIKA FIRENET (available on request)

External room thermostat

Your stove has an interface on the rear wall to which you can connect a customary room thermostat. This requires a 2-pole cable of 0.5 – 0.75 mm² cross-section that you have to connect instead of the cable bridge fitted for delivery.

External connection cable bridge

If the control of your stove is to be assumed by an external room thermostat, you have to connect your external room thermostat (1) instead of the standard integrated cable bridge (2).

The connected room thermostat can be operated in either MANUAL or AUTOMATIC MODE. In both MODES, the current set heat output is used, in AUTOMATIC MODE the heating times set at the stove can also be activated.

You can see whether the external demand is currently activated in the INFO main menu in submenu item Info - inputs.

If your stove receives an external demand to stop operation, it takes approx. 5 minutes until it switches off. All further settings required to your thermostat can be taken from the respective room thermostat operating instructions.

Note Operation is not possible unless either a cable bridge or an external room thermostat is connected. The external demand has priority over all operating modes (MANUAL/AUTOMATIC/COMFORT).

Option RIKA FIRENET 2nd Generation

Only for combination and pellet stoves with touch panel version V2.29 or higher.

The FIRENET module connects your stove to the Internet. You can operate the stove with any Internet-enabled device (tablet, PC, Smartphone ...). So you retrieve the operational status, various information and make your settings remotely.

For further information, please contact your dealer.

RIKA VOICE

for combi and pellet stoves with touch display, version V2.26 or above, only and in combination with the RIKA Firenet module and Amazon Alexa

RIKA VOICE allows you to control your RIKA stove by simply speaking to it. Power on or off, switching between modes or adjusting the preferred heat output or room temperature: a few words is all it takes!

More detailed information could be obtained at www.rika.at or from your dealer.

6. BRIEF INFORMATION ON FUEL - PELLETS

What are pellets?

Wood pellets are a standardised fuel. Every manufacturer must adhere to certain conditions in order to enable flawless, energy-efficient heating. Pellets are made from wooden waste, from sawmills and planning workshops, as well as from residue from forestry operations. These starting products are crushed, dried, and pressed into pellet fuel without any bonding agent.

ENplus – Pellets

This ENplus standard sets benchmarks in the European pellet market. The traceability of pellets is ensured thanks to the use of identification numbers. The pellet manufacturers' production facilities and manufacturing processes are reviewed every year. A quality assurance system ensures the pellets comply with the requirements of the new standard and that the conditions for trouble-free heating are guaranteed.



Wood pellet specification according to ENplus – A1

Parameter	Measure	ENplus-A1
Diameter	mm	6 (±1) ²⁾
Length	mm	3,15–40 ³⁾
Buld density	kg/m ³	≥ 600
Calorific value	MJ/kg	≥ 16,5
Water content	Ma.-%	≤ 10
Fine fraction (< 3,15 mm)	Ma.-%	≤ 1
Mechanical rigidity	Ma.-%	≥ 97,5 ⁴⁾
Ash content	Ma.-% ¹⁾	≤ 0,7
Ash softening temperature	(DT) °C	≥ 1200
Chlorine content	Ma.-% ¹⁾	≤ 0,02
Sulphur content	Ma.-% ¹⁾	≤ 0,03
Nitrogen content	Ma.-% ¹⁾	≤ 0,3
Copper content	mg/kg ¹⁾	≤ 10
Chrome content	mg/kg ¹⁾	≤ 10
Arsenic content	mg/kg ¹⁾	≤ 1
Cadmium content	mg/kg ¹⁾	≤ 0,5
Mercury content	mg/kg ¹⁾	≤ 0,1
Lead content	mg/kg ¹⁾	≤ 10
Nickel content	mg/kg ¹⁾	≤ 10
Zinc content	mg/kg ¹⁾	≤ 100

1) in an anhydrous state

2) diameter must be specified

3) a maximum of 1% of the pellets may be longer than 40 mm, max. length is 45 mm

4) the limit value of ≥ 97,7 Ma.-% applies when conducting measurements with a lignotester (internal control)

Your pellet stove is only approved for the burning of pellets of tested quality. Please ask your pellet stove dealer for tested fuel and a list of monitored fuel manufacturers.

Note

Only burn pellets that have been inspected according to ENplus - A1. Using poor quality or prohibited pellet fuel will have a negative effect on the function of your pellet stove and can also lead to the warranty becoming null and void, as well as the product liability connected with this.

Note

The temperature and output of your stove may vary due to different pellet qualities.

Note

The delivery rate displayed for pellet consumption (INFO - PARAMETERS - FEED RATE TOTAL) may differ from the actual quantity due to the different quality and bulk density of the pellets. This does not constitute grounds for complaint.

Note

Burning straw, maize, woodchips etc. is not permitted! Observe waste incineration legislation! Non-observance of these regulations makes void all warranty and guarantee claims and may impair the safety of the unit!

Pellet container refilling during operation

Note

CAUTION when filling! Avoid direct contact between the plastic bag and the hot stove. Immediately remove all pellets that have fallen on the hot stove or next to the container!

We recommend always having a suitable amount of pellets in the container to prevent the fire from extinguishing due to a lack of fuel. Check the level frequently. However the container lid should be kept closed, except during filling.

If you refill the container during operation (open the container lid), the fan will speed up and the pellet auger will stop; operation will only be continued once the container lid is closed again.

Pellet container capacity: (see TECHNICAL DATA)

Pellet storage

In order to guarantee problem free burning of the wooden pellets, it is imperative necessary to store the fuel as dry as possible and free from impurities.

Pellets should not be kept in sacks outdoors or stored in a manner where they are exposed to the environment. This can lead to blockages in the screw conveyor.

Note

Screw stoppers are excluded from the warranty.

Amount of fuel

	Nominal Load	Part Load
Amount of fuel	~1,6 kg/h*	~0,6 kg/h*
Burn time at full pellet hopper	~15 h*	~41 h*

*Practical values may vary depending on pellet quality.

Note

Pellet consumption depends on the size of the pellets. The larger the pellet, the slower the feed and vice versa.

Time-burning fireplace (INT)

Your stove corresponds to the INT type and is therefore a time-burning fireplace. This is intended for operation at short intervals over any period of time by successive filling.

Note

If the stove is heated in continuous operation, this results in increased wear, especially of the thermally stressed parts. The cleaning intervals may be shortened. It is therefore essential to observe the cleaning and maintenance instructions!

7. INSTRUCTIONS FOR COMMISSIONING PROTOCOL

Operator instruction

This is one of the most important points in the putting into operation. The following points must be clearly communicated to the operator by an authorised service technician:

Stove functions

- Explanation of the processes in the stove during ignition, normal operation, cleaning phase etc.

Control

- Refilling the pellet container
- Functions and settings
- Options / Accessories
- Programming heating times

Operating instructions

- Handover and reference to the content of the following points

Warranty terms

- Difference between warranty (statutory) and guarantee (voluntary)
- Terms of guarantee
- Determination of wearing parts
- Reference to pellet quality to be used and the consequences of poor quality

Cleaning instructions

- Regular cleaning is necessary for regular heating operation
- The ash drawer is to be emptied regularly
- The flue gas pipes are to be cleaned once or twice in the heating season depending on stove type; by a specialist company is best

Note

We recommend at least once a year to have all maintenance carried out by your RIKA dealer.

Combustion

- All doors must close tightly to prevent intake of false air



COMMISSIONING REPORT

for RIKA pellet and combi stoves.

Installation address

Surname, forename

Street, number

Post-code, city

E-mail, phone

Device data

Device type

Serial number

Cladding undamaged? YES NO

Electrical peripherals

Connection socket grounded

Room thermostat Model

FIRENET Model

Inspection of system and safety components

Smooth operation of flues gas flap checked (combi stove)

Smooth operation of backfire safety flap checked (combi stove)

Differential pressure sensor (building) YES NO

Installation

Proper installation according to installation and user manuals YES NO

Comments

RIKA retailer

Retailer stamp

Software version

Display version

Year of production

GSM modem Function checked

Phone provider

Fire alarm in place? YES NO

Fire-proof floor covering in place? YES NO

Other

Room height

Room ventilation YES NO

Exhaust hood (outdoor connection) YES NO

WC extraction YES NO

8. ASSEMBLY / DISASSEMBLY PANELS

Note

Only work on the unit when the mains plug has been disconnected and the stove has cooled down completely.



Note

During assembly / dismantling do not allow objects (screws etc.) to fall into the pellet container – they can block the screw conveyor and damage the stove.



Note

During any conversion work, take particular care of your fingers and any panels and stove attachments. Select soft bases to prevent scratches to your living space furniture and stove panels.



Remove the cover by simply lifting.

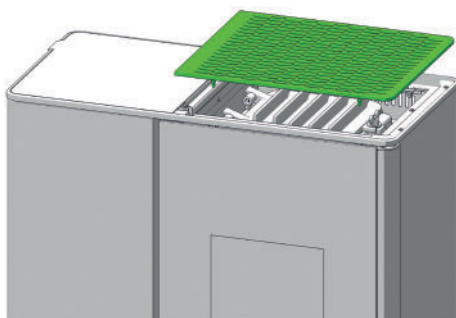

Open the pellet container lid until it stops, in this position, it stays open.

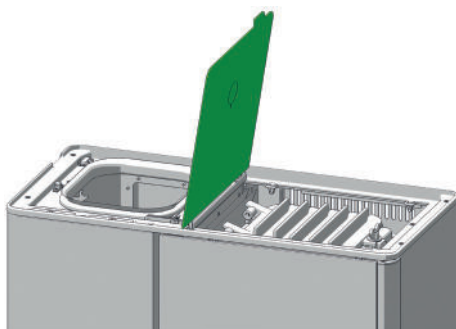

Now remove the 4 screws on the side panel and lift the side wall.

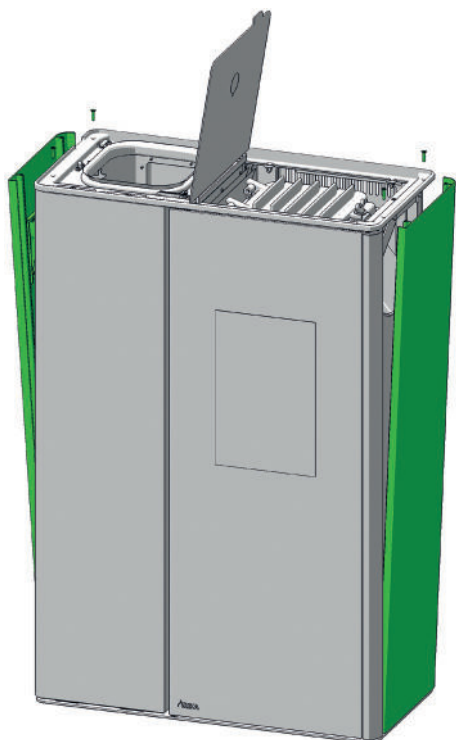

Steelshell

Remove these screws and tilt the panel, then lift it up.

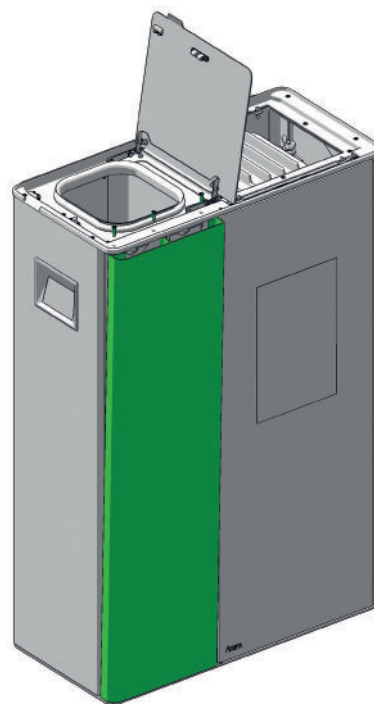

Stone

For the right front stone remove the self-locking hexagon nut including the covering plate which serves to seal the pellet container.

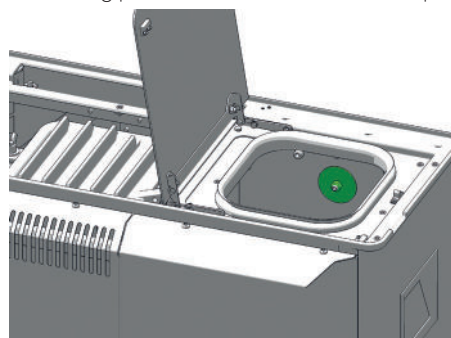

Now lift the stone slightly and carefully lift diagonally forward.

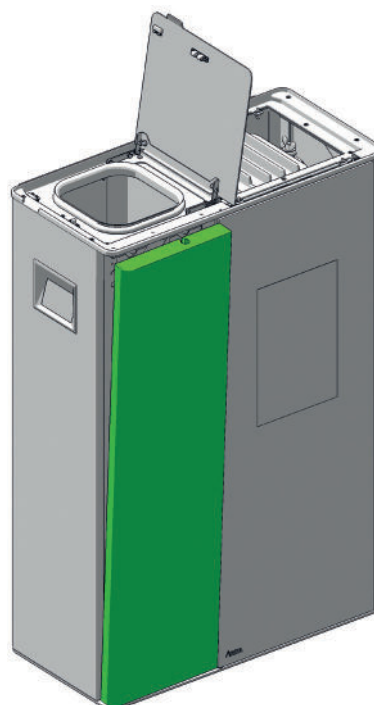

Install the removed parts in reverse order.

9. MAINTENANCE

The frequency with which the stove requires cleaning and the maintenance intervals depend on the fuel you use. High moisture content, ash, dust and chips may more than double the maintenance required. We would like to again point out that only tested and recommended pellets or dry logs may be used as fuel.

Note

Ash may contain embers – only place ash in sheet steel containers. FIRE RISK! In a cold state, dispose it of in the household waste.

Note

We recommend at least once a year to have all maintenance carried out by your RIKA dealer.

Open the combustion chamber door

To open or close the combustion chamber door and the door of the ash-chamber use the included key. This key can be stored on the back of the stove when not in use.

Clean burn pot

If necessary, but at least 1x a week

Note

Clean the fire trough regularly. Only clean when cold, when embers are extinguished!

Despite the automatic ash dumping prior to and during heating operation you have to remove ash or clinker from the combustion chamber, from the fire trough and the turning grid regularly.

Use the cleaning function to put the grid vertical.

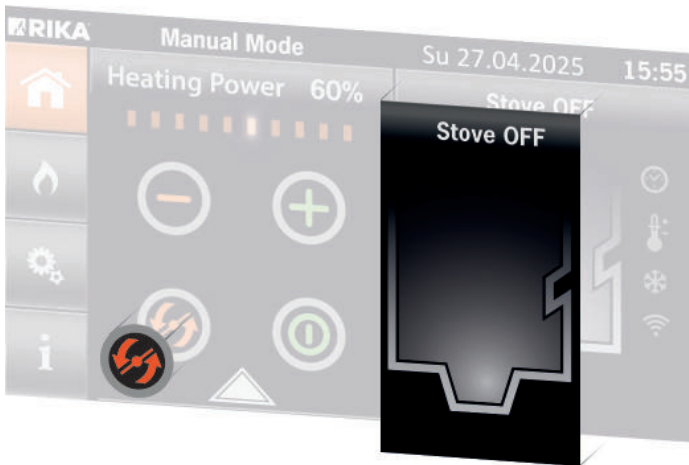

Remove the clinker using the brush supplied and sweep the ashes with a broom in the ash tray. Vacuum out the fire trough.

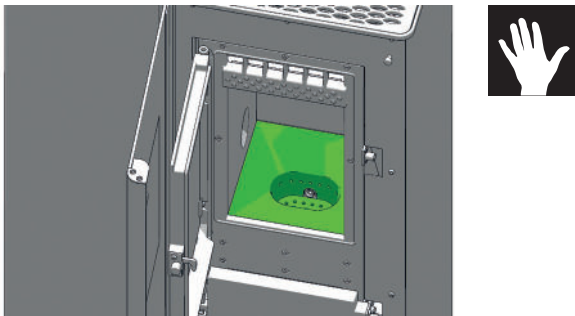

Do not damage the ignition when cleaning with the brush. Vacuum out the pipe of the ignition.

Cleaning the flame temperature sensor

Remove the dust deposits from the sensor at regular intervals. Use a clean cleaning cloth or newspaper.



Empty the ash drawer

Empty the ash drawer regularly. The ash drawer is simply pulled forward with the ash-chamber door open.

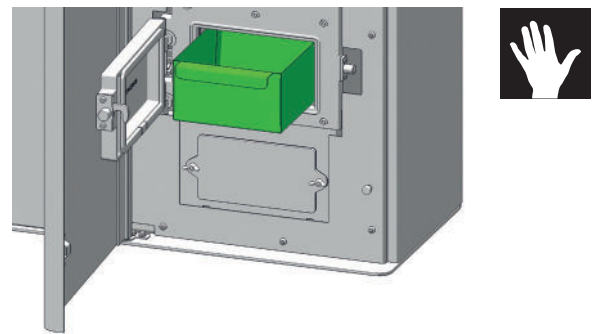

Clean door glass

If necessary

The viewing window becomes coated in the case of solid fuels, particularly with the very fine ash of wood pellets, light or dark depending on the pellet quality (especially with low output). The glass can be cleaned best with a moist cloth. Stubborn dirt can be removed with a special cleaner available from your stove dealer. Usual cleaners containing acid or solvents can be too harsh and damage the glass.

Clean painted surfaces

If necessary

Wipe the painted surfaces with a damp cloth, do not scrub. Do not use solvent-containing cleaners.

10. CLEANING

Tip

Your RIKA dealer will gladly advise you about their service and maintenance offers.



Depending on pellet consumption, a message prompting cleaning of the stove appears on the display in regular intervals. This message can be acknowledged on the Touch Display, while continuing operation. Perform a cleaning cycle at the next opportunity.

Subsequently, reset the counter in the SETTINGS menu / RESETS submenu, as per operating instructions of TOUCH DISPLAY.

Tip

The message will only stop reappearing once you have reset the feed volume in the SETTINGS / Resets menu.



Note

Your stove must be switched off and cooled before any maintenance work is performed. Only work on the unit when the mains plug has been disconnected.



Clean convection air openings

Vacuum clean any dust deposits from the convection air openings at regular intervals.

The stove should be cleaned thoroughly prior to the start of the heating season to prevent excess odour.

Note

To prevent your stove from overheating of the internal components, do never cover the convection openings!



Clean combustion air intake

Note

Only when the stove is cold! You could vacuum out embers – FIRE RISK!



If necessary, clean the air intake with a Hoover.

Clean the pellet container

Do not refill the completely emptied container immediately; remove the residues (dust, chippings etc.) from the bottom of the container. The unit must be disconnected from the mains!

Clean the flue pipes

annually

Remove the flue pipes. Inspect and clean the chimney connection. Brush off any soot and dust deposits in the fire and in the flue pipes and vacuum.

Note

Accumulated fly ash in the flue gas channels may impair the performance of the stove and pose a safety risk.



Check bearings

annually

All built in bearings (pellet screw, turning grid) should be checked. Clean or replace bearings depending on condition.

Check seals

annually

Check the condition of the seals at least once a year. Repair or replace seals depending on condition.

Note

Only intact seals ensure your stove works perfectly!



Tip

You will find the seals and sealing kit in the spare part overview.



Cleaning the flue gas channels and flue gas collecting duct

The flue gas channels are situated beneath and beside the combustion chamber.

Open the decorative glass door by pushing the button on the display before you unplug the stove from the power supply.

Remove the cover by simply lifting.

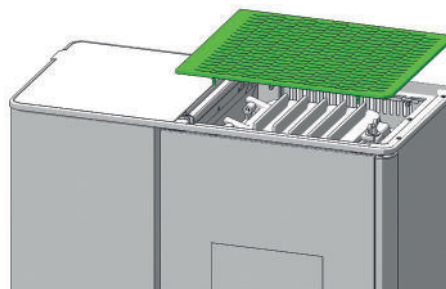

Loosen the wing nut on the lid of the cleaning opening, tilting the eyescrew sideways.

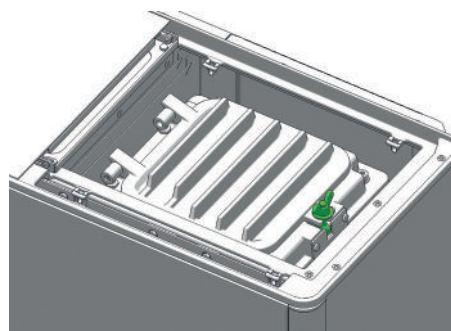

Open the lid as far as the stop.

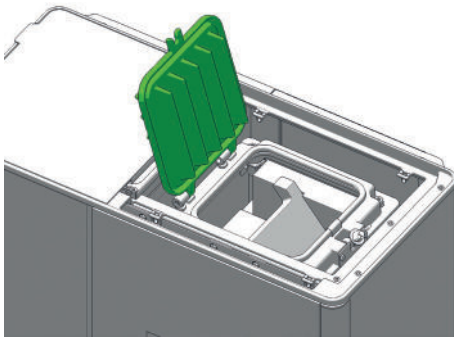

Remove the top horizontal baffle plate.

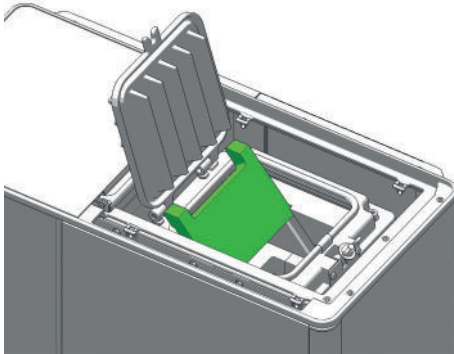

Now clean the flues and baffles with the supplied brush. Vacuum the combustion residues with a vacuum cleaner.

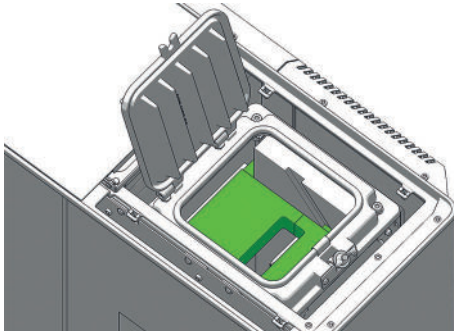

Unscrew the two wing screws under the ash door and remove the outer cleaning lid.

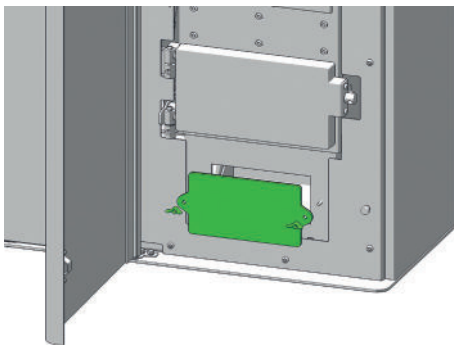

Vacuum the combustion residues off the flue gas collecting duct, especially the areas to the side flues.

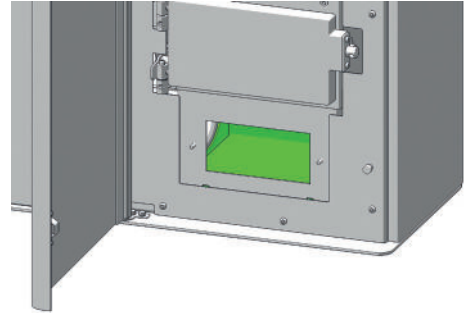

Install the removed parts in reverse order again.

SONO RAO:

Unscrew the two wing screws and remove the inner cleaning lid.

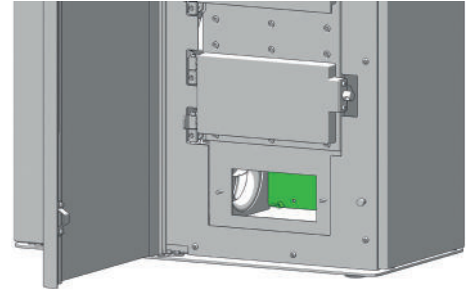

Vacuum the combustion residues off the flue gas collecting duct, especially the areas to the side flues.

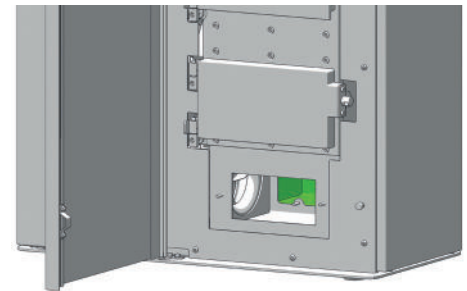

Install the removed parts in reverse order again.

Note

Your stove may suck in false air via incorrectly sealed cleaning covers; this air may lead to incomplete combustion in the fire trough and thus piling up of pellets. DANGER of FIRE!

To ensure the proper operation of your pellet stove, replace the defect (porous, frayed) seals after cleaning and maintenance.



11. PROBLEMS - POSSIBLE SOLUTIONS

Problem 1

Fire burns with weak, orange flame. Pellets heap up in fire trough, window soots up.

Cause(s)

- Insufficient combustion air
- Poor chimney draught
- Stove is sooted over inside

Possible solutions

- Remove any ash or clinker from the fire trough that may block the air inlets. (see CLEANING/MAINTENANCE)
- If possible swap to better pellet quality.
- Check whether flue gas pipes are blocked with ash (see CLEANING/MAINTENANCE).
- Check whether the air intake or flue tubes are blocked.
- Check door and cleaning cover seals for leaks (see CLEANING/MAINTENANCE)
- Clean fan (see CLEANING/MAINTENANCE)
- Have service performed by authorised specialist company.
- The window has to be cleaned from time to time (see CLEANING/MAINTENANCE)

Problem 2

Stove smells strongly and smokes outside.

Cause(s)

- Burning-in phase (taking into service)
- Stove has accumulated dust and/or dirt

Possible solutions

- Wait to end of burning-in phase and vent the room sufficiently.
- Vacuum off any dust deposits from the convection air openings at regular intervals

Problem 3

Flue gas discharge when wood is added and during heating phase.

Cause(s)

- Leaking cleaning openings
- Chimney draught too low
- Leaking flue pipe connection

Possible solutions

- Check seals and replace (fire door, cleaning lid, ..)
- Check for blockages in the chimney
- Check connections and if necessary re-seal

Note

Please note that checks on the control system and wiring may only be performed in unit switched dead. Any repairs may only be performed by trained specialists.



Tip

If a malfunction message occurs, the cause must first be remedied; the unit can be put back into operation by acknowledging the malfunction at the internal unit.



12. TECHNICAL DATA



TECHNICAL DOCUMENTATION

according to commission regulation

(EU) 2015/1185 und 2015/1186

Ecodesign

Contact details of the manufacturer

Manufacturer:	RIKA Innovative Ofentechnik GmbH
Contact:	Andreas Bloderer
Address:	Müllerviertel 20 4563 Micheldorf Austria

Details of the device

Model Identifier:	SONO (RAO / MA)
Equivalent models:	-
Notified body:	Technische Universität Wien, Getreidemarkt 9/166, 1060 Wien, Austria
Notified body no.:	1746
Test report no.:	PL-25026-03-P
Applied harmonised standards:	EN16510-1:2022; EN 16510-2-6:2022
Other applied standards/technical specifications:	-
Indirect heating functionality:	No
Direct heat output:	7,0
Indirect heat output:	-

Characteristics when operating with the preferred fuel

Seasonal space heating energy efficiency η_s :	82%
Seasonal space heating energy efficiency RIKATRONIC η_s :	-
Energy Efficiency Index:	124
Energy Efficiency Index RIKATRONIC:	-

Special precautions for assembly, installation or maintenance

Fire protection and safety distances such as distances to combustibile building materials must be observed!
An adequate supply of combustion air for the appliance must be guaranteed at all times. Air-suction systems can interfere with the combustion air supply!
The flue gas values of the appliance must be observed for the chimney dimensioning!

Characteristics when operating exclusively with the preferred fuel

Heat output			
Nominal heat output	P_{nom}	7,0	kW
Minimum heat output	P_{min}	2,5	kW
Useful efficiency			
Useful efficiency at nominal heat output	$\eta_{th,nom}$	92,6	%
Useful efficiency at minimum heat output	$\eta_{th,min}$	94,2	%
Auxiliary electricity consumption			
At nominal heat output	$e_{l,max}$	0,011	kW
At minimum heat output	$e_{l,min}$	0,009	kW
In standby mode	$e_{l,SB}$	0,004	kW
Permanent pilot flame power requirement			
Pilot flame power requirement	P_{pilot}	NPD	kW

Type of heat output/room temperature control	
single stage heat output, no room temperature control	Yes
two or more manual stages, no room temperature control (**)	No
with mechanic thermostat room temperature control (**)	No
with electronic room temperature control (**)	No
with electronic room temperature control plus day timer (**)	No
with electronic room temperature control plus week timer (**)	No
Room temperature control with presence detection (**)	No
Room temperature control with open window detection (**)	No
with remote control options (**)	No

Details of the fuel

Fuel	Preferred fuel:	Other suitable fuel:	η_s [%]	Space heating emissions at nominal heat output (*)				Space heating emissions at minimum heat output (**)			
				PM	OGC	CO	NO _x	PM	OGC	CO	NO _x
				mg/Nm ³ (13% O ₂)				mg/Nm ³ (13% O ₂)			
Wood logs, moisture content \leq 25 %	No	No	-	-	-	-	-	-	-	-	-
Wood logs RIKATRONIC, moisture content \leq 25 %	No	No	-	-	-	-	-	-	-	-	-
Compressed wood, moisture content < 12 %	Yes	No	82,0	12	1	54	133	23	5	222	133
Other woody biomass	No	No	-	-	-	-	-	-	-	-	-
Non-woody biomass	No	No	-	-	-	-	-	-	-	-	-
Anthracite and dry steam coal	No	No	-	-	-	-	-	-	-	-	-
Hard coke	No	No	-	-	-	-	-	-	-	-	-
Low temperature coke	No	No	-	-	-	-	-	-	-	-	-
Bituminous coal	No	No	-	-	-	-	-	-	-	-	-
Lignite briquettes	No	No	-	-	-	-	-	-	-	-	-
Peat briquettes	No	No	-	-	-	-	-	-	-	-	-
Blended fossil fuel briquettes	No	No	-	-	-	-	-	-	-	-	-
Other fossil fuel	No	No	-	-	-	-	-	-	-	-	-
Blended biomass and fossil fuel briquettes	No	No	-	-	-	-	-	-	-	-	-
Other blend of biomass and solid fuel	No	No	-	-	-	-	-	-	-	-	-

(*) PM = dust, OGC = gaseous organic compounds, CO = carbon monoxide, NO_x = nitrous gases

(**) Only required when applying correction factors F(2) or F(3)

Signed for and on behalf of the manufacturer by:
Andreas Bloderer / product management

RIKA[®]

Innovative Ofentechnik GmbH
A-4563 Micheldorf, Müllerviertel 20
Tel.: +43 (0)75821686-14, Fax DW: -43
www.rika.at

Micheldorf, 31.10.2025



In case of doubt as well as missing or incorrect translations, the German version is the only valid one.

Subject to technical and visual changes as well as layout and printing errors.

Contact details of the manufacturer

Manufacturer:	RIKA Innovative Ofentechnik GmbH
Contact:	Andreas Bloderer
Address:	Müllerviertel 20 4563 Micheldorf Austria

Details of the device

Model Identifier:	SONO (RAO / MA) 6 kW
Equivalent models:	-
Notified body:	Technische Universität Wien, Getreidemarkt 9/166, 1060 Wien, Austria
Notified body no.:	1746
Test report no.:	PL-25026-18-P
Applied harmonised standards:	EN16510-1:2022; EN 16510-2-6:2022
Other applied standards/technical specifications:	-
Indirect heating functionality:	No
Direct heat output:	6,0
Indirect heat output:	-

Characteristics when operating with the preferred fuel

Seasonal space heating energy efficiency η_s :	83%
Seasonal space heating energy efficiency RIKATRONIC η_s :	-
Energy Efficiency Index:	124
Energy Efficiency Index RIKATRONIC:	-

Special precautions for assembly, installation or maintenance

<p>Fire protection and safety distances such as distances to combustible building materials must be observed!</p> <p>An adequate supply of combustion air for the appliance must be guaranteed at all times. Air-suction systems can interfere with the combustion air supply!</p> <p>The flue gas values of the appliance must be observed for the chimney dimensioning!</p>

Characteristics when operating exclusively with the preferred fuel

Heat output			
Nominal heat output	P_{nom}	6,0	kW
Minimum heat output	P_{min}	2,5	kW
Useful efficiency			
Useful efficiency at nominal heat output	$\eta_{th, nom}$	93	%
Useful efficiency at minimum heat output	$\eta_{th, min}$	94,2	%
Auxiliary electricity consumption			
At nominal heat output	$e_{l, max}$	0,015	kW
At minimum heat output	$e_{l, min}$	0,009	kW
In standby mode	$e_{l, SB}$	0,004	kW
Permanent pilot flame power requirement			
Pilot flame power requirement	P_{pilot}	NPD	kW

Type of heat output/room temperature control	
single stage heat output, no room temperature control	Yes
two or more manual stages, no room temperature control (**)	No
with mechanic thermostat room temperature control (**)	No
with electronic room temperature control (**)	No
with electronic room temperature control plus day timer (**)	No
with electronic room temperature control plus week timer (**)	No
Room temperature control with presence detection (**)	No
Room temperature control with open window detection (**)	No
with remote control options (**)	No

Details of the fuel

Fuel	Preferred fuel:	Other suitable fuel:	η_s [%]	Space heating emissions at nominal heat output (*)				Space heating emissions at minimum heat output (**)			
				PM	OGC	CO	NO _x	PM	OGC	CO	NO _x
				mg/Nm ³ (13% O ₂)				mg/Nm ³ (13% O ₂)			
Wood logs, moisture content \leq 25 %	No	No	-	-	-	-	-	-	-	-	-
Wood logs RIKATRONIC, moisture content \leq 25 %	No	No	-	-	-	-	-	-	-	-	-
Compressed wood, moisture content < 12 %	Yes	No	83,0	13	1	52	124	23	5	222	133
Other woody biomass	No	No	-	-	-	-	-	-	-	-	-
Non-woody biomass	No	No	-	-	-	-	-	-	-	-	-
Anthracite and dry steam coal	No	No	-	-	-	-	-	-	-	-	-
Hard coke	No	No	-	-	-	-	-	-	-	-	-
Low temperature coke	No	No	-	-	-	-	-	-	-	-	-
Bituminous coal	No	No	-	-	-	-	-	-	-	-	-
Lignite briquettes	No	No	-	-	-	-	-	-	-	-	-
Peat briquettes	No	No	-	-	-	-	-	-	-	-	-
Blended fossil fuel briquettes	No	No	-	-	-	-	-	-	-	-	-
Other fossil fuel	No	No	-	-	-	-	-	-	-	-	-
Blended biomass and fossil fuel briquettes	No	No	-	-	-	-	-	-	-	-	-
Other blend of biomass and solid fuel	No	No	-	-	-	-	-	-	-	-	-

(*) PM = dust, OGC = gaseous organic compounds, CO = carbon monoxide, NO_x = nitrous gases

(**) Only required when applying correction factors F(2) or F(3)

Signed for and on behalf of the manufacturer by:
Andreas Bloderer / product management

RIKA[®]

Innovative Ofentechnik GmbH
A-4563 Micheldorf, Müllerviertel 20
Tel.: +43 (0)75821686-14, Fax DW: -43
www.rika.at

Micheldorf, 31.10.2025

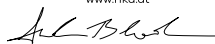

In case of doubt as well as missing or incorrect translations, the German version is the only valid one.

Subject to technical and visual changes as well as layout and printing errors.

Dimensions, weight and connection

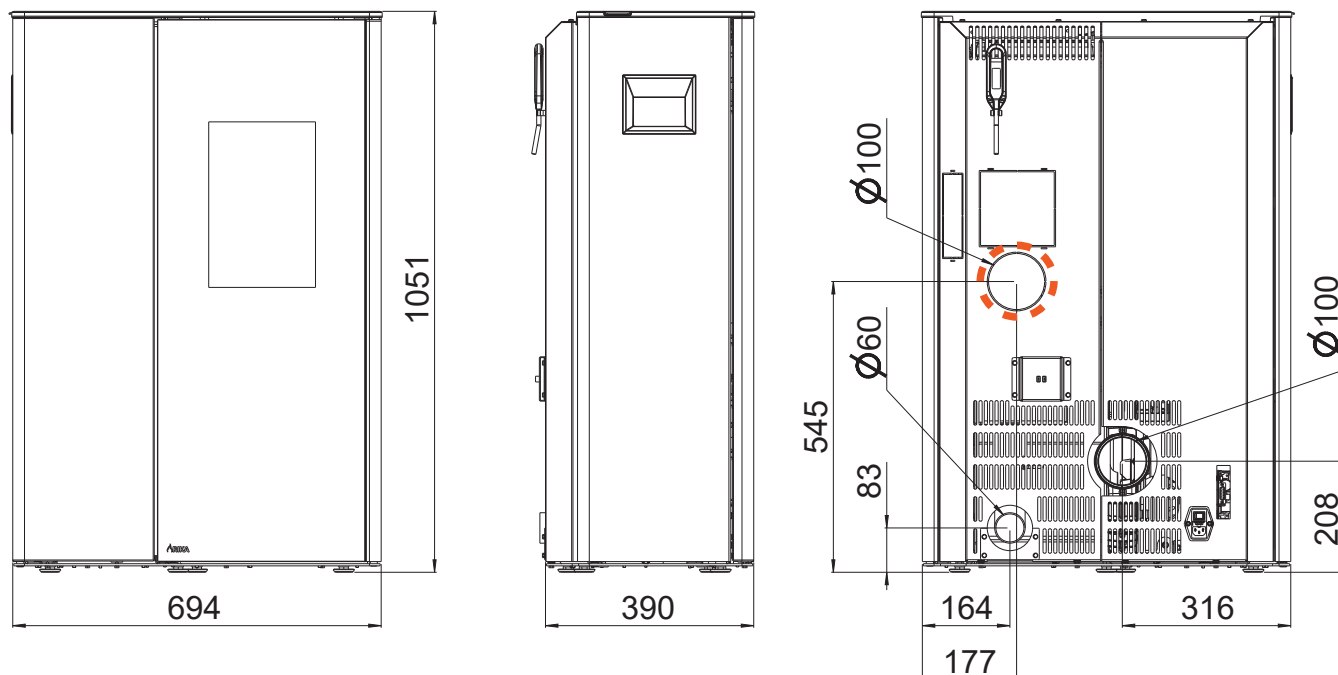

Dimensions

H	Height	[mm]	1051
L	Length	[mm]	390
W	Width	[mm]	694

Weight

m1	Mass of fireplace without steel panelling	[kg]	~ 145
m2	Mass of fireplace with steel panelling / with stone panelling	[kg]	~ 150 / ~175
m_{chim}	Maximum load through the chimney	[kg]	-

Flue pipe connection

d_{out}	Diametre of the flue gas connection	[mm]	100
	Top connection Connection height	[mm]	-
	Depth from rear wall to middle of flue pipe	[mm]	-
	Side distance	[mm]	-
	Rear connection height	[mm]	208
	Rear connection side distance	[mm]	316
	Side connection connection height	[mm]	-
	Depth to lateral connection	[mm]	-

Fresh air connection

	Diameter	[mm]	60
	Connection height	[mm]	83
	Lateral distance	[mm]	164
	Floor connection side distance	[mm]	-
	Floor connection depth	[mm]	-

Convection air connection MULTIAIR

	Diameter	[mm]	100
	Connection height	[mm]	545
	Lateral distance	[mm]	177

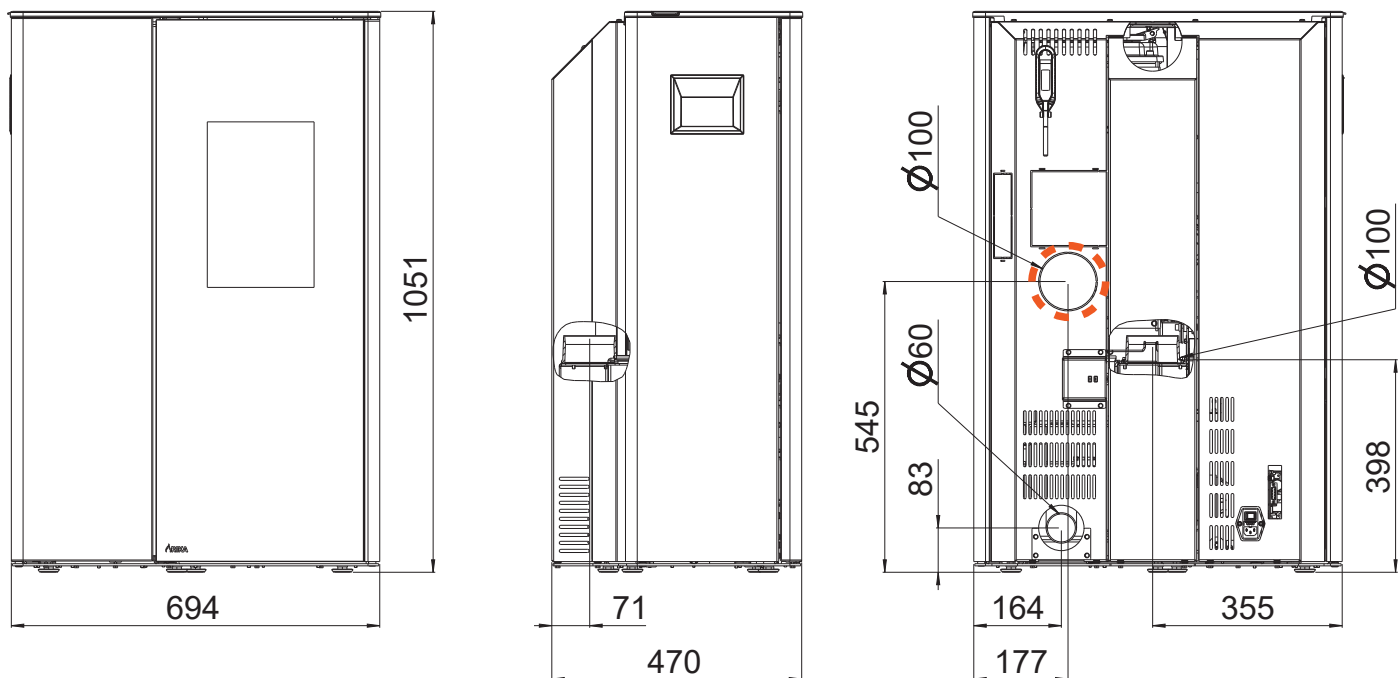

Dimensions

H	Height	[mm]	1051
L	Length	[mm]	470
W	Width	[mm]	694

Weight

m1	Mass of fireplace without steel panelling	[kg]	~ 150
m2	Mass of fireplace with steel panelling / with stone panelling	[kg]	~ 155 / ~180
m_{chim}	Maximum load through the chimney	[kg]	-

Flue pipe connection

d_{out}	Diametre of the flue gas connection	[mm]	100
	Top connection Connection height	[mm]	398
	Depth from rear wall to middle of flue pipe	[mm]	71
	Side distance	[mm]	355
	Rear connection height	[mm]	-
	Rear connection side distance	[mm]	-
	Side connection connection height	[mm]	-
	Depth to lateral connection	[mm]	-

Fresh air connection

	Diameter	[mm]	60
	Connection height	[mm]	83
	Lateral distance	[mm]	164
	Floor connection side distance	[mm]	-
	Floor connection depth	[mm]	-

Convection air connection MULTIAIR

	Diameter	[mm]	100
	Connection height	[mm]	545
	Lateral distance	[mm]	177

Technical Details

General		7 kW	6 kW	
P_{nom}	Nominal heat output	[kW]	7	6
P_{SHnom}	Nominal room heat output	[kW]	7	6
P_{part}	Partial load heat output	[kW]	2,5	2,5
P_{SHpart}	Partial load room heat output	[kW]	2,5	2,5
	Fresh air requirement	[m ³ /h]	16	13
	MULTIAIR-Output*	[kW]	0,6 - 1,8	0,6 - 1,4
	MULTIAIR-Air volume*	[m ³ /h]	40 - 75	40 - 75
	Space heating capacity depending on the house insulation	[m ³]	50 - 190	50 - 160
η_{nom}	Efficiency at nominal heat output	[%]	92,6	93
η_{part}	Efficiency at partial load heat output	[%]	94,2	94,2
	Fuel consumption	[kg/h]	0,6 - 1,6	0,6 - 1,3
	Pellet container capacity**	[l]/[kg]	39/~25	39/~25
	CO ₂ content	[%]	11,3	10,4
CO_{nom}	CO-Emission at nominal heat output with an oxygen content of 13% O ₂	[mg/m _N ³]	54	52
CO_{part}	CO-Emission at partial load heat output with an oxygen content of 13% O ₂	[mg/m _N ³]	222	222
NO_{xnom}	NO _x -Emission at nominal heat output with an oxygen content of 13% O ₂	[mg/m _N ³]	133	124
NO_{xpart}	NO _x -Emission at partial load heat output with an oxygen content of 13% O ₂	[mg/m _N ³]	133	133
OGC_{nom}	Hydrocarbon emission at nominal heat output with an oxygen content of 13% O ₂	[mg/m _N ³]	1	1
OGC_{part}	Hydrocarbon emission at partial load heat output with an oxygen content of 13% O ₂	[mg/m _N ³]	5	5
PM_{nom}	Dust Emission at nominal heat output with an oxygen content of 13% O ₂	[mg/m _N ³]	12	13
PM_{part}	Dust Emission at partial load heat output with an oxygen content of 13% O ₂	[mg/m _N ³]	23	23
$\phi_{fg nom}$	Flue gas mass flow at nominal heat output	[g/s]	4,8	4,5
$\phi_{fg part}$	Flue gas mass flow rate at partial load heat output	[g/s]	3	3
T_{snom}	Flue gas temperature at the flue gas connection at nominal heat output	[°C]	148	134
T_{spart}	Flue gas temperature at the flue gas connection at partial load heat output	[°C]	79	79
P_{nom}	Minimum conveying pressure at nominal heat output	[Pa]	12	12
P_{part}	Minimum delivery pressure at partial load heat output	[Pa]	10	10
P_{min}	Minimum supply pressure for chimney calculation	[Pa]	3	3
V_h	Space heat loss when the fireplace is not in operation	[m ³ /h]	-	-
η_s	Annual space heating utilisation factor	[%]	82	83
EEI	Energy Efficiency Index		124	124
E, f	Supply voltage, frequency	[V]/[Hz]	230/50	230/50
W_{max}	Maximum electrical power consumption	[W]	150	150
W_{\emptyset}	Average electrical power consumption	[W]	20	20
	Fuse	[A]	2,5	2,5
eI_{SB}	Consumption of electrical auxiliary energy in standby mode	[kW]	0,011	0,015
eI_{max}	Consumption of electrical auxiliary energy at nominal heat output	[kW]	0,009	0,009
eI_{min}	Consumption of electrical auxiliary energy at partial load heat output	[kW]	0,004	0,004
INT	Time-burning operation			
$T\text{-Klasse}$	Chimney designation		T200G	

*with a two meter MULTIAIR line in combination with RIKA design outlet, values may differ in practice.

**Capacity in kg may vary due to different pellet bulk densities

Note

The criterion for the end of the test cycle for pellet stoves is 3 hours.
For log wood stoves, the CO₂ criterion is 4%.



Spare parts overview Exploded view

Note

Only original parts supplied by the manufacturer may be used.

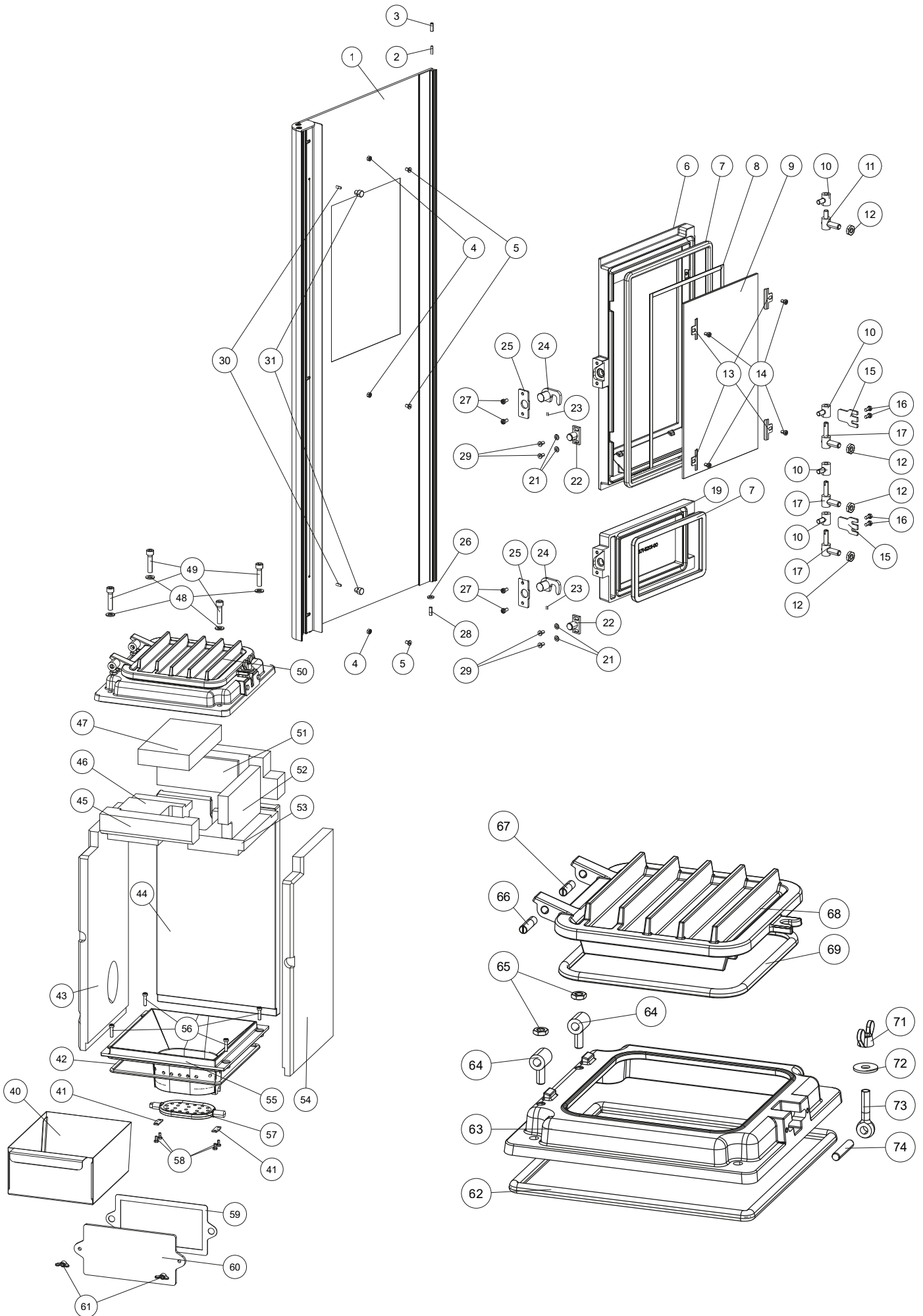

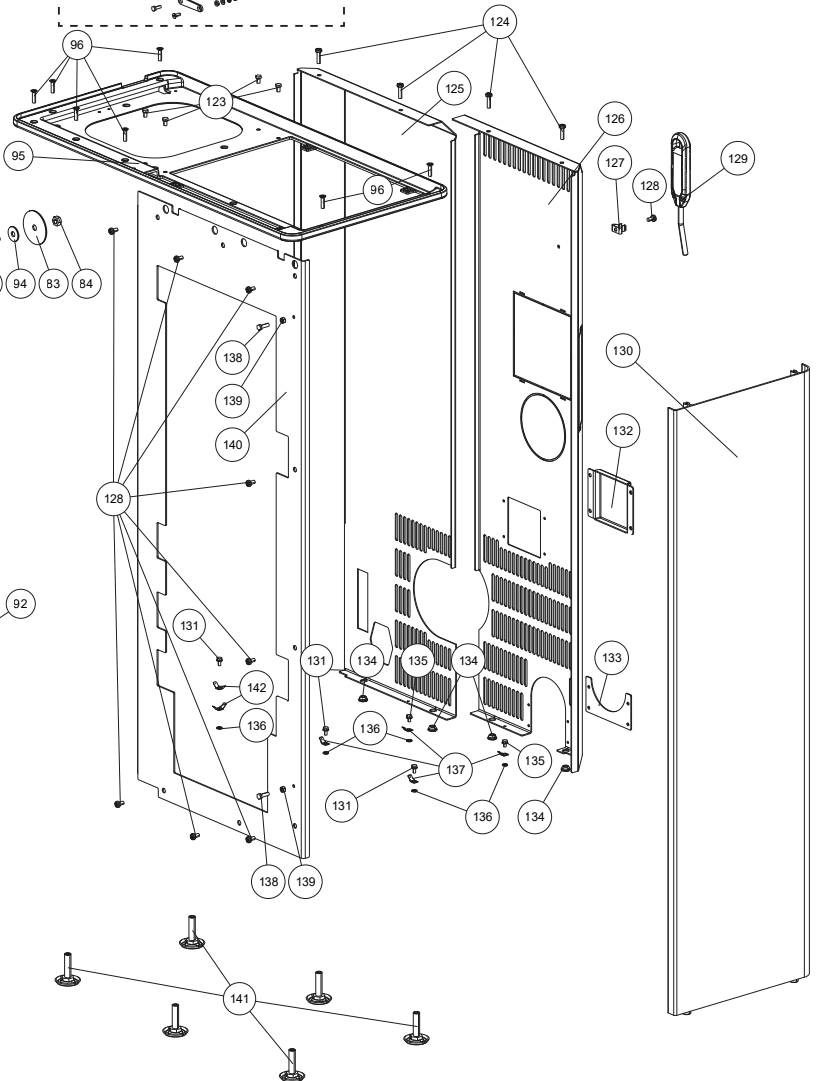
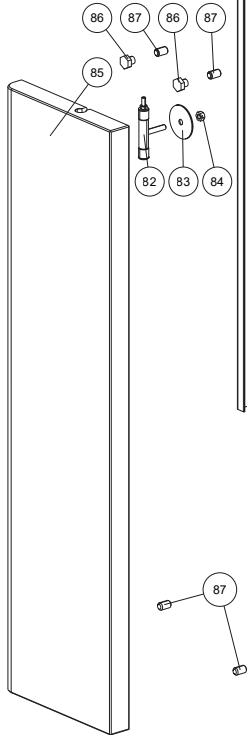
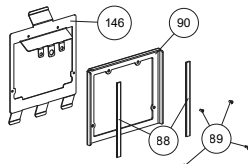
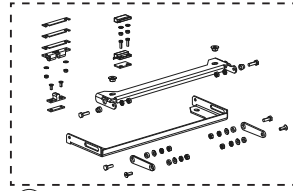
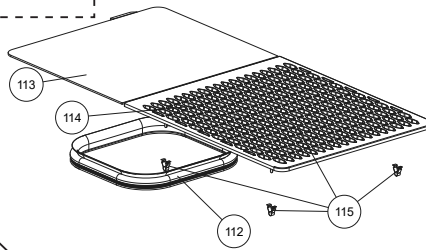
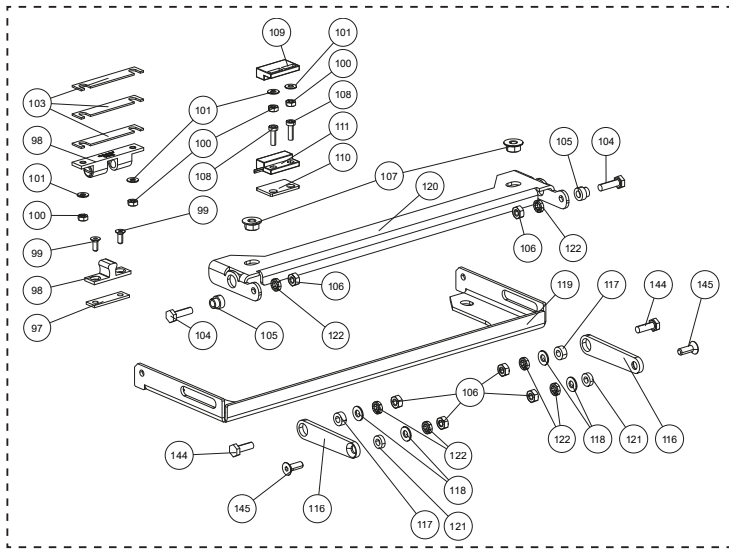

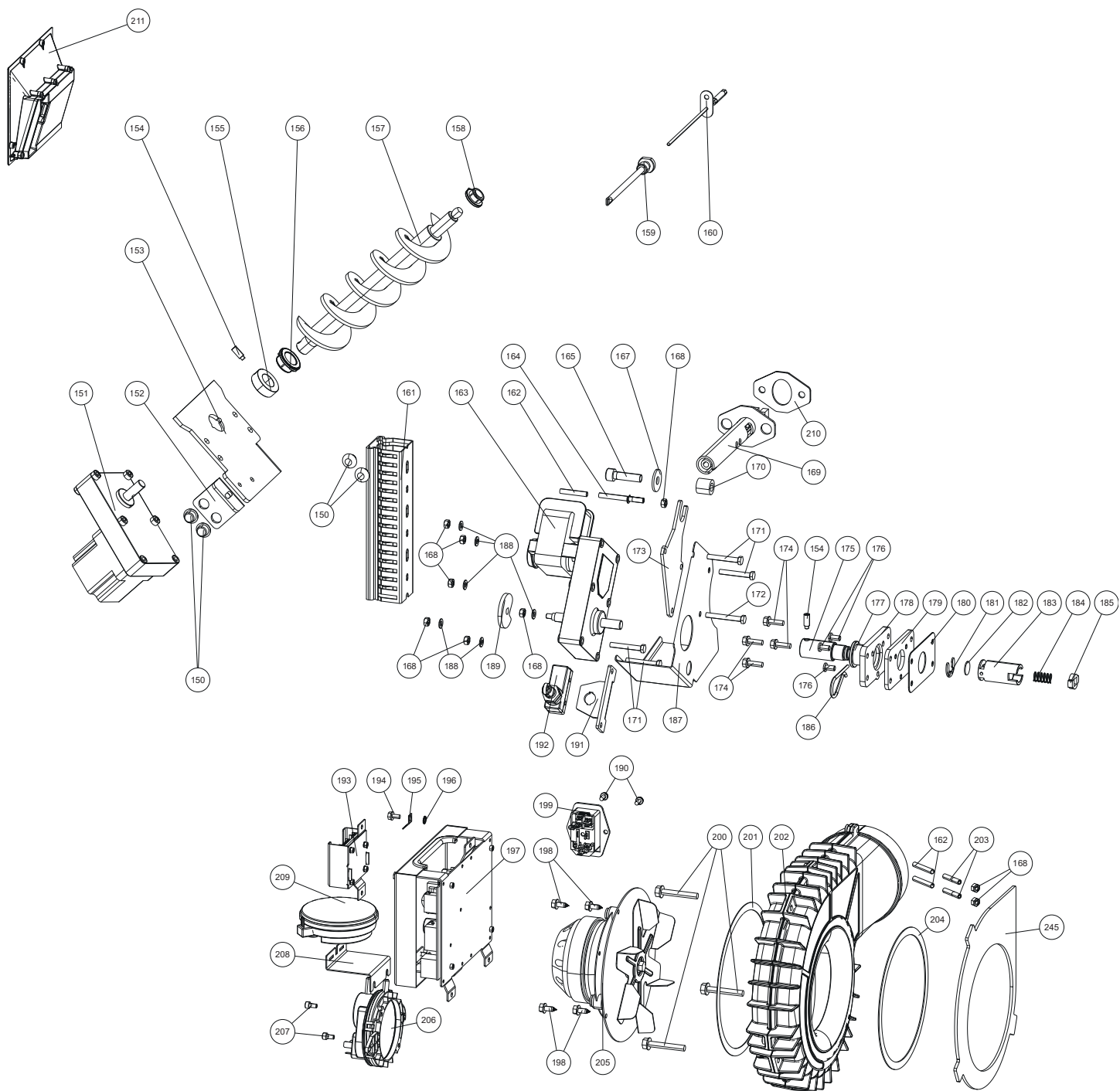

SONO option MULTIAIR

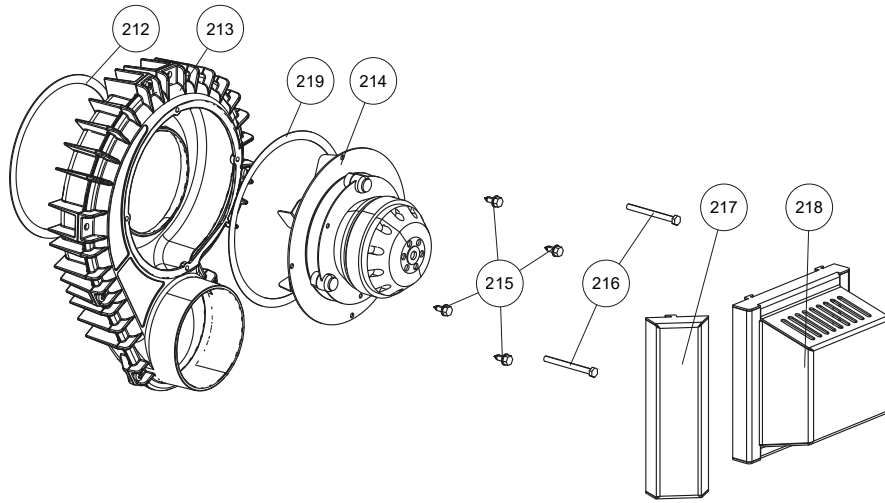

SONO RAO

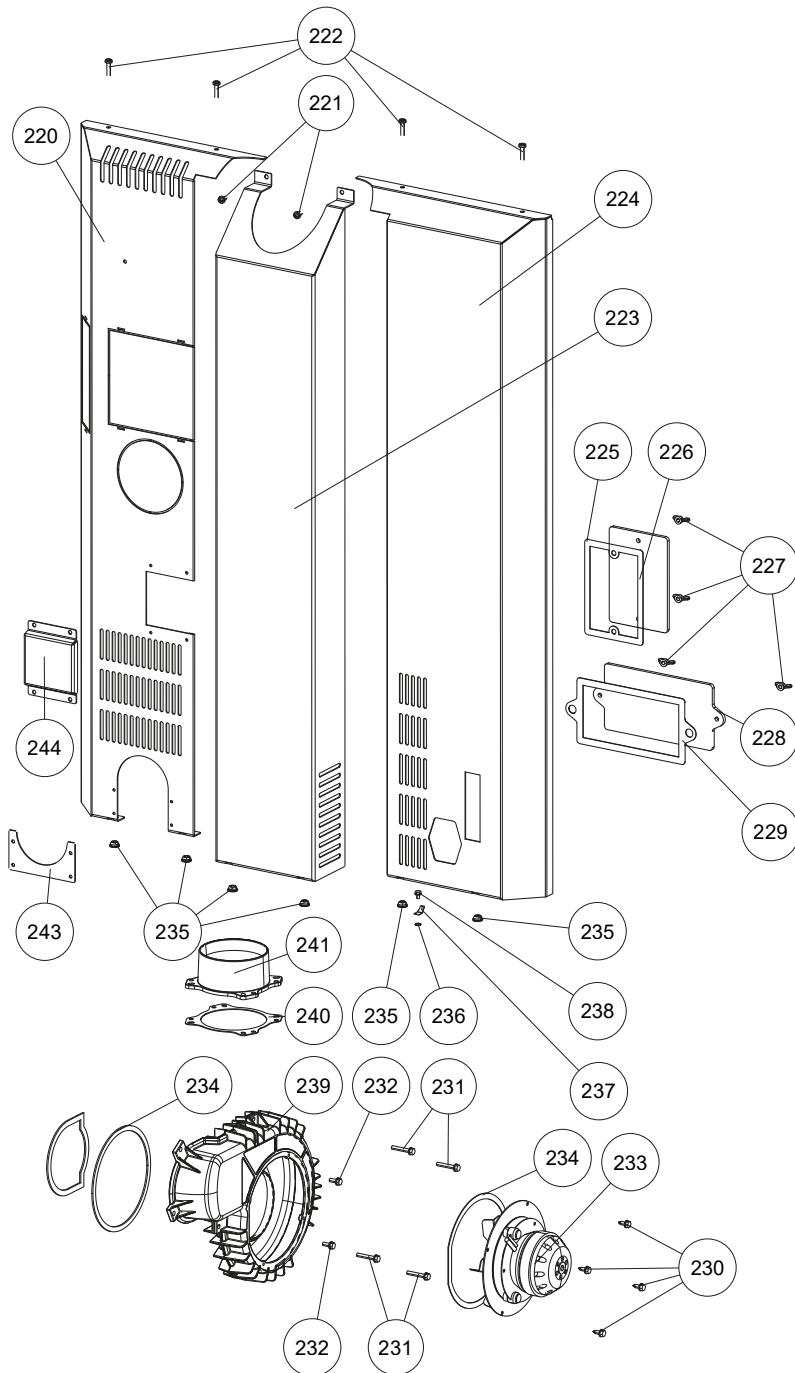

Spare part overview article numbers

Nr.	Art.Nr.	Description
1	B18723	Decorative door assy
2	N112425	Grub screw
3	N111803	Grub screw M05x16
4	N106175	Hexagonal nut M05
5	N108830	Fillister head screw M05x08
6	Z35464	Combustion chamber door black
	B17408	Combustion chamber door assy
7	N112551	Round sealing strip grey D11 (1m)
8	N103693	Flat seal black 8x2
9	Z35856	Front door glass
10	B17524	Hinge black
11	B17405	Hinge
12	N111780	Hexagonal nut
13	L00475	Glass holder
14	N112201	Hexagon socket screw M05X08
15	L02645	Door stop base plate
16	N111950	Hexagonal screw M05x10
17	B16814	Hinge
19	Z35465	Front door black assy
21	N111965	Washer M05
22	B12322	Closure plate
23	N111956	Grub screw
24	B17407	Shutter
25	L02647	Closure plate
26	Z38164	Washer
27	N112190	Hexagon socket screw M05X10
28	N112698	Headless screw M05X16
29	N108485	Allen screw M05X10
30	N112720	Grub screw M04X12
31	N112027	Magnet
40	L03782	Ash drawer
41	L02726	Small plate
42	N111631	Round sealing cord grey D06
43	Z38166	Firebrick lining left
44	Z38134	Cast rear panel black
45	Z38170	Firebrick lining front
46	Z38171	Baffle plate left
47	Z38370	Firebrick lining cover
48	N105049	Flat washer black
49	N112047	Hexagon socket screw M08x35
50	B18720	Combustion chamber lid assy
51	Z38169	Firebrick lining rear
52	Z38168	Firebrick lining cover right
53	Z38172	Baffle plate right
54	Z38167	Firebrick lining right
55	Z38131	Fire trough
56	N112707	Allen screw M05X20
57	Z38132	Turning grid
58	N111835	Hexagonal screw M04X08
59	Z36566	Sealing
60	Z36000	Cleaning cover
61	N112077	Wing nut
62	N107048	Sealing cord black D10
63	Z38133	Combustion chamber lid
64	B18133	Hinge
65	N112696	Hexagonal nut M08
66	N112427	Headless screw M08X30
67	N112428	Headless screw M08X25
68	Z36921	Cleaning opening
69	N112551	Round sealing strip grey D11 (1m)

Nr.	Art.Nr.	Description
71	N112387	Wing nut
72	N112509	Washer M08
73	N112386	Swing bolt M08X40
74	N112390	Cylindrical pin
80	Z38163	Washer
81	L03783	Open-end wrench
82	B17390	Stone retainer assy
83	L02239	Cover plate
84	N111970	Hexagonal nut M08
85	Z38174	Soapstone front
	Z38175	White stone front
86	N112442	Hexagonal screw M12X10
87	N112708	Grub screw M12X20
88	N103693	Flat seal black 8x2
89	N112031	Screw 2,5X06
90	L03724	Holder touch-display
91	B18727	Side casing steel panel left
92	B18730	Steel front
93	N111962	Hexagonal screw M08X20
94	N112509	Washer M08
95	Z38035	Cover frame
96	N113220	Countersunk head screw M5X25
97	L01502	Lock washer
98	N110461	Double ball catch
99	N112446	Hexagonal countersunk screw M03x08
100	N112143	Hexagonal nut M03
101	N112144	Washer M03
103	L02349	Lock washer
104	N112723	Hexagonal screw M04X14
105	Z38165	Hinge pin
106	N111975	Hexagonal nut M04
107	N112142	Flange nut
108	N111842	Hexagon socket M03x10
109	N111732	Magnetic switch top part
110	L01445	Switch spacer
111	N111733	Magnetic switch bottom part
112	N112600	Container seal
113*1	B18794	Container lid assy
114	B18725	Convection cover
115	Z36001	Snap spring
116*1	L03812	Hinge part
117	Z34489	Spacer
118	N107150	Washer
119*1	L03726	Hinge guidance
120*1	L03727	Hinge
121	Z34490	Spacer
122	N112071	Wedge retaining ring
123	N111964	Hexagonal screw M05X08
124	N112186	Self-tapping screw M05X20
125	L03703	Rear wall left
126	L03700	Rear wall right
127	Z35691	Spring plug
128	N112185	Self-tapping screw M05x10
129	N112018	Key
130	B18726	Side casing steel panel right
131	N111877	Self-tapping screw M04X08
132	L03702	Cover
133	L03701	Cover
134	N111730	Grommet
135	N111805	Self-tapping screw M04x06

Note: Please consider the powdercoated parts can differ slightly in colour and colour effects though they are elaborated in high quality. Fairing parts with minor damage cannot be repaired and must therefore be replaced as spare parts. There is no matching RAL colour for the painted fairing parts.

Nr.	Art.Nr.	Description
136	N101888	Washer M04
137	Z27423	Ground connection
138	N112140	Hexagonal screw M05X16
139	N112274	Hexagonal nut M05
140	Z38260	Cover panel
141	N112490	Levelling screw black
142	N111478	Ground connection
144	N109390	Hexagonal screw M04X12
145	N111856	Hexagonal countersunk screw M04x12
146*2	L03918	Holder touch-display
149	N112499	Grub screw M6x16
150	Z18997	Rubber buffer
151	N112030	Screw motor, stepless
152	L03711	Pressure bracket
153	L03710	Retaining plate motor
154	N112499	Grub screw M6x16
155	Z11915	Lock ring conveyer screw
156	Z35182	Friction bearing D16
157	B16967	Auger
158	Z35183	Friction bearing D10
159	B16053	Sensor tube
160	B16114	Temperature sensor
161	Z36991	Cable channel
162	N111551	Silicon hose
163	N112014	Turning grid motor assy
164	Z36760	Pressure Pipe
165	N112378	Hexagon socket screw M08X30
167	N112509	Washer M08
168	N112274	Hexagonal nut M05
169	B17166	Ceramic ignition
170	N112609	Silicon hose
171	N111806	Hexagonal screw M05X35
172	N101570	Hexagonal screw M05x40
173	L02643	Motor plate
174	N111947	Self-tapping screw M05x16
175	Z38161	Drive shaft
176	N108485	Allen screw M05X10
177	N102688	Sinter bearing ID16
178	Z35852	Bearing clamping plate
179	L02641	Bearing plate
180	Z36167	Ceramic seal
181	N112125	Circlips
182	L03781	Small plate
183	Z35854	Intermediate shaft turning grid
184	N108131	Pressure spring
185	L01875	Driving plate turning grid
186	N112470	Spring clip
187	L03484	Heat protection
188	N111965	Washer M05
189	L02646	Washer M05
190	N112703	Self-tapping screw M04x08
191	L02644	Retaining plate
192	N111825	Contact switch
193	B16030	Additional motherboard for motor, incl. cable
194	N111877	Self-tapping screw M04X08
195	Z27423	Ground connection
196	N101888	Washer M04
197	B16561	Mainboard USB1

Nr.	Art.Nr.	Description
198	N106989	Hexagonal screw
199	Z38387	IEC mains socket
200	N105627	Self-tapping screw M06x40
201	N100475	Flat packing white 8x2
202	B16155	Induced draft fan housing
203	Z37701	Pressure Pipe
205	B19655	Fan motor packed
206	N112102	Differential pressure switch
207	N112059	Allen screw M04X08
208	L03638	Holder plate
209	N112473	Differential pressure sensor
210	Z36290	Seal for ignition
211	B17158	Touch-display screwable

MULTIAIR

212	N100475	Flat packing white 8x2
213	B17370	Induced draft fan housing
214	B19656	Fan motor MULTIAIR packed
215	N106989	Hexagonal screw
216	N112283	Hexagonal screw M05X55
217	L03797	Cover MULTIAIR
218	L03796	Cover MULTIAIR

Version RAO

220	L03705	Rear wall
221	N112186	Self-tapping screw M05X20
222	N112185	Self-tapping screw M05x10
223	L03706	Cover RAO
224	L03704	Rear wall
225	Z36567	Sealing
226	Z35999	Cleaning cover
227	N112077	Wing nut
228	Z36000	Cleaning cover
229	Z36566	Sealing
230	N106989	Hexagonal screw
231	N112305	Self-tapping screw M05x30
232	N108313	Self-tapping screw M05x12
233	B19655	Fan motor packed
234	N100475	Flat packing white 8x2
235	N111730	Grommet
236	N101888	Washer M04
237	Z27423	Ground connection
238	N111805	Self-tapping screw M04x06
239	B16951	Induced draft fan housing
240	Z37830	Pipe adapter seal
241	Z37844	Pipe adapter
243	L03701	Cover
244	L03702	Cover
245	Z40268	Seal Induced draft fan
	B18722	Wiring harness
	Z35018	Cable for touch-screen 1,25 m
	Z34841	Cable for additional motherboard
	Z38075	Cable for differential pressure sensor
	N111604	Fuse 2,5 A
	E16472	Sealing kit SONO
	B19297	Set turning grid connection SONO
	*1	up to serial number 1433830 order part B18794
	*2	from serial number 1464906

Note: Please consider the powdercoated parts can differ slightly in colour and colour effects though they are elaborated in high quality. Fairing parts with minor damage cannot be repaired and must therefore be replaced as spare parts. There is no matching RAL colour for the painted fairing parts.

13. GUARANTEE CONDITIONS

We recommend having the installation performed by a RIKA-certified technician.

These guarantee conditions only apply for the European mainland. For all other countries, the separate conditions of the importer in the respective country apply. In cases of doubt, or in the case of missing or incorrect translations, the German version is always the sole valid version.

In the interest of ensuring damage limitation in good time, the guarantee claim should be sent in writing to the RIKA specialist or contract dealer.

In this event, the following documents must be presented:

- Written reason for complaint
- Invoice
- Commissioning record
- Model name and serial number

RIKA GUARANTEE

5 YEARS

on the welded stove body.

Up to 5 years or 10,000 kg of consumed pellets for pellet stoves.

The RIKA guarantee is a commercial or manufacturer's guarantee (subject to certain exceptions).

This relates exclusively to defects in the material and processing, and to the supply of replacement parts free of charge. Working hours and travel times are not covered by the manufacturer's guarantee.

The guarantee is conditional on the following:

- Only original parts supplied by the manufacturer must be used.
- Professional installation of the stove in compliance with the respective operating manual valid at the time of purchase.
- The stove must be connected by a professional certified for that type of stove.
- The commissioning is performed by a RIKA-certified technician.

If these points are not complied with, the guarantee claim is void!

Any costs incurred by the manufacturer as a result of an unjustified guarantee claim will be charged back to the claimant. Likewise excluded from the guarantee is any damage resulting from or caused by non-compliance with the manufacturer's instructions for operating the appliance, e.g. overheating, use of non-approved fuels, unprofessional interference with the appliance or the flue pipe, a flue suction that is incorrectly adjusted to the appliance or is insufficient or too strong, condensation water, non-performance of or inadequate maintenance or cleaning, non-compliance with the applicable building regulations, improper operation by the operator or third parties, transport and handling damage.

STATUTORY WARRANTY PROVISIONS REMAIN UNAFFECTED BY THE GUARANTEE!

14. WARRANTY CONDITIONS

As a consumer, you are entitled to the warranty, which covers any defects at the time of delivery. The warranty is two (2) years from the date of delivery of the stove.

See the respective general terms and conditions of business and warranty conditions of the RIKA dealer.

The warranty does not cover:

1. Wearing parts (normal wear and tear not resulting from a defect)
2. Parts in contact with fire, e.g. glass, combustion troughs, grates, baffle plates, deflectors, combustion chamber cladding (e.g. refractory clay), ceramics, ignition elements, sensors, combustion chamber sensors and temperature monitors
3. Paint, surface coatings (e.g. handles, cover panels)
4. Seals
5. Natural stone, thermal stone, etc.

valid from: 01.07.2023

15. DISPOSAL INFORMATION

RIKA Innovative Ofentechnik GmbH is ensuring that its products are eco-friendly throughout the product life cycle. This is why our commitment for electronic products goes beyond the end of their product life cycle.

Note

For proper disposal of the device, we recommend contacting a local waste disposal company.

Note

Please contact your RIKA specialist dealer for professional disassembly/dismantling of the device.

Note

We recommend that you remove the parts that come into contact with the fire, such as glass, fire trough, grates, draught plates, baffle plates, combustion chamber linings (e.g. fireclay), ceramics, ignition elements, sensors, combustion chamber sensors and temperature monitors and dispose of them in the household waste.

Information on the individual components of the device

- **Electrical or electronic components:** Remove the electrical or electronic components from the device by disassembling them. These components must not be disposed of in the residual waste. Proper disposal should be carried out via the waste electrical equipment take-back system.
- **Fireclay in the combustion chamber:** Remove fireclay components that have been installed in the combustion chamber from the appliance. If present, fastening elements must be removed beforehand. Fireclay components that come into contact with the fire or flue gas must be disposed of; reuse or recycling is not possible.
- **Vermiculite in the combustion chamber:** Remove vermiculite that has been installed in the combustion chamber from the appliance. If present, fastening elements must be removed beforehand. Vermiculite in contact with fire or flue gas must be disposed of, reuse or recycling is not possible.
- **Glass ceramic pane:** Remove the glass ceramic pane using a suitable tool. Remove the seals and separate them from the frame if present. Transparent glass ceramic can generally be recycled, but must be separated into decorated and non-decorated panes. The glass ceramic pane can be disposed of as construction waste.
- **Sheet steel:** Disassemble the sheet steel components of the device by unscrewing or flexing (alternatively by mechanical crushing). If present, remove the seals beforehand. Dispose of the sheet steel parts as metal scrap.
- **Cast iron:** Disassemble the components of the cast iron device by unscrewing or flexing (alternatively by mechanical crushing). If present, remove gaskets beforehand. Dispose of the cast parts as metal scrap.
- **Natural stone:** Remove existing natural stone mechanically from the unit and dispose of as construction waste.
- **Gaskets (glass fibre):** Remove the gaskets mechanically from the device. These components must not be disposed of with residual waste, as waste glass fibre cannot be destroyed by incineration. Dispose of gaskets as glass and ceramic fibres (artificial mineral fibres).
- **Metal handles and decorative elements:** If present, remove or dismantle metal handles and decorative elements and dispose of them as metal scrap.

Note

Please observe the local disposal possibilities for all components.

Extract from the waste code of the European Waste List Regulation

Waste code	Waste type
15 01 03	Wooden packaging
17 01 03	Tiles and ceramics
17 02 02	Glass
17 04 05	Iron and steel
17 05 04	Soil and stones

Electronic Waste

In accordance with the European Directive (2012/19/EU) Waste Electrical and Electronic Equipment (WEEE) and other local regulations, RIKA supports the setup of take-back systems and recycling infrastructures.

Old devices can easily be returned to the municipal waste collectors for recycling purposes. Please observe the national regulations to that end.



The device may not be disposed of in the normal household waste.

16. COMPLIANCE WITH EU REGULATIONS



This product complies with the requirements of the European Community.

Hereby, RIKA Innovative Ofentechnik GmbH declares that this device is in compliance with the essential requirements and other relevant provisions of Directive 2014/30/EU, 2014/35/EU, 2014/65/EU and 2011/1185/EU.

The most recent and valid version of the DoC (Declaration of Conformity) can be viewed at www.rika.at



RIKA Innovative Ofentechnik GmbH

Müllerviertel 20

4563 Micheldorf / AUSTRIA

Tel.: +43 (0)7582/686 - 41, Fax: -43

verkauf@rika.at

www.rika.at

In case of doubt as well as missing or incorrect translations, the German version is the only valid one. Subject to technical and visual changes as well as layout and printing errors.

© 2026 | RIKA Innovative Ofentechnik GmbH