

SUMO / SUMO RAO SUMO MULTIAIR



Operating manual











TABLE OF CONTENTS

Explanations to symbols.....	3
1. IMPORTANT INFORMATION	5
Packaging.....	5
General warning and safety information.....	5
Electrical connection.....	5
First heating.....	5
The correct chimney connection.....	6
Multiple and mixed occupancy.....	6
Room air-independent operation.....	6
Room air-dependent operation.....	6
Convection air conduction.....	6
2. INSTALLING THE STOVE	7
Connection to the chimney.....	7
Connecting to a steel chimney.....	7
Combustion air.....	7
Feeding in external combustion air.....	7
3. FIRE PROTECTION	8
Minimum distances.....	8
Radiation range.....	9
Floor protection.....	9
4. TECHNOLOGY AND SAFETY FUNCTIONS	10
Operating comfort.....	10
Top efficiency - lowest emissions.....	10
DAR - Dynamic Air Regulation.....	10
Pressure monitoring.....	10
Low-temperature shutdown.....	10
Electrical excess current protection.....	10
Automatic cleaning cycle.....	10
Component monitoring.....	10
Auger motor monitoring.....	10
Power failure (during heating).....	10
Power failure (during the initial stage).....	10
5. COMFORT OPTIONS	11
Room sensor, Radio room sensor.....	11
Interface for various options.....	11
External request.....	11
Serial interface.....	11
USB connection.....	11
External room thermostat.....	11
External connection cable bridge.....	11
Option RIKA FIRENET 2nd Generation.....	11
RIKA VOICE.....	11
6. BRIEF INFORMATION ON FUEL - PELLETS	12
What are pellets?.....	12
Wood pellet specification according to ENplus – A1.....	12
Pellet container refilling during operation.....	12
Pellet storage.....	12
Time-burning fireplace (INT).....	12
Amount of fuel.....	12
7. INSTRUCTIONS FOR COMMISSIONING PROTOCOL	13
Operator instruction.....	13

8. OPTIONAL CONNECTION	14
Changing the connection to the left side.....	14
9. MAINTENANCE	15
Open the combustion chamber door	15
Cleaning the fire trough	15
Cleaning the flame temperature sensor	15
Empty the ash drawer	15
Cleaning the door glass.....	15
Cleaning painted surfaces.....	15
10. CLEANING	16
Cleaning the convection air openings.....	16
Combustion air - intake.....	16
Cleaning the pellet container	16
Cleaning the flue pipes	16
Bearings.....	16
Checking door seal.....	16
Cleaning the flue gas channels and flue gas collecting duct	16
11. PROBLEMS - POSSIBLE SOLUTIONS	18
Problem 1.....	18
Problem 2.....	18
Problem 3.....	18
12. TECHNICAL DATA	20
Dimensions, weight and connection - SUMO.....	22
Dimensions, weight and connection - SUMO RAO.....	23
Dimensions, weight and connection - SUMO MULTIAIR.....	24
Technical Details	25
Spare parts overview Exploded view - SUMO / SUMO RAO	26
Spare part overview article numbers - SUMO / SUMO RAO.....	28
Spare parts overview Exploded view - SUMO MULTIAIR	30
Spare part overview article numbers - SUMO MULTIAIR.....	32
13. GUARANTEE CONDITIONS	34
14. WARRANTY CONDITIONS	34
15. DISPOSAL INFORMATION	35
Information on the individual components of the device	35
Extract from the waste code of the European Waste List Regulation	35
Electronic Waste.....	35
16. COMPLIANCE WITH EU REGULATIONS	35

Explanations to symbols

 ...Important note	 ...Manually	 ...Hexalobular T25
 ...Useful tip	 ... Allen key #2, #3	
 ...complies with EU regulations	 ...Read and follow the operating instructions	 ...do not dispose of in household waste



A STOVE IS ALWAYS MORE THAN „JUST“ A SOURCE OF HEAT.

Dear customer,

We would like to thank you for purchasing our high-quality stove. With this quality product, we not only want to bring warmth into your home, but also create cosiness and comfort.

We are proud to be able to offer you a product that is not only functional, but also impresses with its attractive design. We attach great importance to quality and sustainability and are convinced that you will enjoy your new stove for a long time.

To ensure the long-term performance and efficiency of your stove, it is important to carry out regular cleaning and maintenance work. Here are some important points to bear in mind:

1. clean the inside of the oven regularly to remove deposits and dirt. You will find detailed information on this under „CLEANING & MAINTENANCE“.
2. have the oven serviced regularly by a specialist to ensure that all components are working properly and show no signs of wear.
3. please also observe the recommended safety measures to avoid accidents and damage.

By carrying out these simple care and maintenance measures regularly, you can ensure that your stove functions optimally and that you can enjoy it for a long time.

We wish you a pleasant „oven time“ and thank you for your trust and support.

Yours sincerely

Karl Stefan Riener

Karl Philipp Riener

Stefan Riener

1. IMPORTANT INFORMATION

Packaging

Your first impression is important to us!

The packaging of your new stove provides excellent protection against damage. However damage to the stove and accessories may still occur during transport.

Note

Therefore please check your stove on receipt for damage and completeness! Report any deficiencies to your dealer immediately! Pay particular attention during unpacking that the stone panels remain intact. Scratches to the material can easily occur. Stone panels are excluded from the warranty

The packaging of your new stove is environmentally neutral to a great extent.

Tip

The wood used in the packaging has not been surface treated and may therefore be burnt in your stove. The cardboard and film (PE) can be disposed of via the municipal waste collection for recycling.

General warning and safety information

Observance of the introductory general warning information is imperative.

- Read the entire manual thoroughly before installing and putting the stove into service.
- The owner of the small firing installation or the person authorised to dispose of the small firing installation must keep the technical documentation and present it to the authorities or the chimney sweep on request.
- Observe the national and European standards and local regulations that apply to the installation and operation of the fireplace!
- RIKA stoves should only be installed in rooms with normal humidity (dry areas according to VDE 0100 Part 200). The furnaces are not splash water protected and may not be installed in wet areas. The minimum size of the installation space is 40 m³.
- Before installing the stove, make sure that the load-bearing capacity of the substructure can withstand the weight of the stove
- Only approved transport equipment with sufficient load carrying capacity may be used with your heating appliance.
- Your heating appliance is not suitable for use as a ladder or stationary scaffolding.
- Under no circumstances may the stove be operated with defective door seals. The seals must be replaced with original RIKA seals by a specialised company.
- The burning of fuel releases heat energy that lead to extensive heating of the stove surfaces, doors, door and operating handles, glass, flue pipes and possibly the front wall. Refrain from touching these parts without appropriate protective clothing or equipment e.g. heat-resistant gloves or means of operation (operating handle).
- Make your children aware of this particular danger and keep them away from the stove during heating.
- Only burn approved heating materials.
- The combustion or introduction of highly flammable or explosive materials (petrol, petrol-type lamp oils, paraffin, barbecue coal lighter, ethyl alcohol or similar liquids), such as empty spray cans etc. in the combustion chamber and storing them near the stove is strictly prohibited due to the danger of explosion.
- No light or inflammable clothing is to be worn when post-heating.
- Make sure that no embers fall out of the combustion chamber onto combustible material.
- Placing non-heat resistant objects on the stove or near it is prohibited.

- Do not place clothing on the stove to dry.
- Laundry racks etc. must be placed at a sufficient distance to the stove – ACUTE DANGER OF FIRE!
- When your stove is burning, the use of highly inflammable and explosive materials in the same or adjacent rooms is prohibited.
- If the stove is heated in continuous operation, the cleaning intervals are shorter. Increased wear, especially of the thermally stressed parts, is the result. Please therefore strictly follow the requirements for cleaning and maintenance!

Note

Waste and liquids may not be burnt in the stove!

Note

To prevent your stove from overheating of the internal components, do never cover the convection fins!

Note

CAUTION when filling the pellet container. The opening of the pellet container is sufficiently dimensioned to ensure easy filling. Take great care that no pellets drop to the convection fins and the hot stove body. This can cause a lot of smoke.

Tip

Therefore we recommend refilling the pellet container at a cold stove.

Note

Your stove will expand and contract during the heating and cooling phase. This can sometimes lead to slight bending or cracking noises. This is normal and is no reason for a complaint.

Note

No changes may be made to the fireplace. This will also invalidate the guarantee and warranty.

Electrical connection

The stove is supplied with an approx. 2m long connecting cable with a Euro-plug. This cable is to be connected to a 230Volt/50Hz socket. The average electrical power consumption is about 20 Watt in heating operation. And approx. 150 Watt during automatic ignition. The connection cable must be laid so that there is no contact to any sharp edges or hot surfaces of the stove.

Danger to life!

Operation with a damaged connection cable is not permitted! If the connection cable is damaged, it must be replaced immediately by a qualified specialist company to avoid further danger.

Note

No liability is accepted for damage to the appliance caused by improper connection and use and the warranty is void.

First heating

The stove body, just as various steel parts, cast iron parts and the flue pipes are painted with a heat resistant paint. During the first heating the paint dries out completely. This may cause a slight smell. Touching or cleaning the painted surfaces during the curing should be avoided. The hardening of the paint is finished after the first heating with high power.

The correct chimney connection

To select the connection and to ensure a correct connection between the stove and the chimney (flue), please read the section on INSTALLING THE STOVE or ask your local master chimney sweep.

- Flue pipes pose a particular source of hazard regarding gas leaks and fire. Get the advice of an authorised specialist company for the layout and assembly.
- Please observe the corresponding installation guidelines for walls panelled with wood when connecting your flue pipes to the stove.
- Observe the formation of flue gas (atmospheric inversion) and draughts when the weather is unfavourable.
- Infeed of too little combustion air can lead to smoke in the rooms or to flue gas leaks. Hazardous deposits in the stove and chimney may also occur.
- If flue gas escapes, let the fire burn out and check whether all the air inlet openings are free and the flue gas pipes and the stove pipe are clean. If in doubt notify the master chimney sweep since draught malfunctions may be connected to your chimney.
- The combustion chamber door is to be kept closed when the stove is not in operation.
- Fouling of the chimney i.e. deposits of highly inflammable materials such as soot and tar and subsequently fire in the chimney may occur if the chimney is miscalculated and dimensioned wrong and if wet wood is used.
- If fire in the chimney occurs, disconnect the mains plug of the stove. Phone the fire brigade and get yourself and other residents out of harm's

Multiple and mixed occupancy

- Your stove is suitable for multiple and mixed use and may only be operated with the combustion chamber door closed.
- A chimney calculation in accordance with EN13384-2 is required.
- Mixed use only in conjunction with BROKO safety device in accordance with DIBt approval Z-43.13-485.
- Please note the different national regulations.

Room air-independent operation

Your stove corresponds to type CC and can therefore also be operated as a room air-independent pellet stove.

Provided that the required combustion air is supplied from outside via sealed pipes, the stove may also be installed in utilisation units that are permanently airtight in accordance with the state of the art, as well as in utilisation units that are equipped with mechanical ventilation or extraction systems. (See SUPPLY OF EXTERNAL COMBUSTION AIR).

The built-in differential pressure switch checks the differential pressure between the combustion chamber and the installation room required for proper operation.

If the required differential pressure is not sufficient, the stove cannot be put into operation or operation is stopped for safety reasons.

No flue gases can escape in dangerous quantities. An additional safety device is not necessary.

The stove must not be installed with ventilation systems that have a negative pressure below -15 Pa.

Note

Please always observe the applicable local regulations and rules in consultation with your local chimney sweep.



Room air-dependent operation

If the stove is installed without an external air supply, it is considered to be room air-dependent.

In this case, all the combustion air is taken from the installation room via the central air intake connection on the rear of the stove.

Therefore, make sure that there is always enough fresh air for proper combustion and that no room air extraction systems are acting on the stove.

The amount of fresh air required can be found in the technical data list. In combination with ventilation systems (e.g. controlled ventilation systems, extractor fans, etc.), it must be ensured that the stove and the ventilation system are mutually monitored and secured (e.g. via a differential pressure controller, etc.). The necessary combustion air supply of approx. 20 m³/h must be guaranteed.

Convection air conduction

only for stoves with MULTIAIR

- The amount of air and temperature of one fan is designed to heat one additional room.
- Clarify the connection situation with the responsible authority.
- The max. temperature of the convection air is 180 °C at the air outlet.
- The convection air canal should be as short as possible.
- Keep the number of deflections as small as possible.

Some models have a cover over the MULTIAIR fan ex works to prevent direct heat emission to the wall:



example

Operation without this cover or without attached convection pipes is not allowed. If you do though no warranty and no liability is accepted for damage.

Note

Please pay attention to the national and country-specific building and fire regulations when connecting the convection air pipes. Installation and assembly must be performed by a trained specialist only.



2. INSTALLING THE STOVE

Note

Assembly may only be performed by authorised specialist companies.

Note

Please observe the regional safety and building regulations. Please contact your master chimney sweep in this context.

Note

Only use heat-resistant sealing materials as well as corresponding sealing strips, heat-resistant silicon and rock wool.

Note

Also take care that the flue does not project into the free cross-section of the chimney.

Note

In case of room-air independent operation the stove pipe connections must be tightly sealed permanently. Use a heat-proof silicon to position the stove pipe on the conical supports of the flue tube nozzles and for insertion in the chimney flue lining.

Note

The stove should not be pushed on unprotected floors.

Tip

Strong corrugated cardboard, cardboard or e.g. old carpet is useful to assist assembly and as a base. The stove can also be pushed on this cardboard or carpet.

We recommend original flue pipes from RIKA for proper connection.

Connection to the chimney

- The device must be connected to a flue that is approved for solid fuels and is insensitive to moisture. The moisture insensitivity may vary if the flue calculation results in a dry operation.
- The temperature class of the flue gas system (chimney and flue pipe) must be at least class T200 soot fire resistant for pellet stoves in accordance with EN16510-2-6 and at least class T400 soot fire resistant for all other appliances.
- The chimney must have a diameter of min. 100 mm for pellet stoves and 130 mm -150 mm for log wood stoves depending on the diameter of the flue pipes.
- Avoid long flue pipes to the chimney. The horizontal length of the flue pipe should not exceed 1.5 metres.
- Avoid to many bends of the flue gas pipes. There should not be more than 3 bends in the exhaust pipe.
- Please use a connection with a cleaning opening.
- Connections must be made of metal and must meet the requirements of the standard (install the connections airtight).
- Before installing a chimney calculation must be made. The evidence must be performed for single occupancy to EN13384-1 and EN13384-2 for multiple occupancy.
- The maximum draft of the chimney should not exceed 15 Pa.
- The derivation of the flue gases must be guaranteed even during a temporary power outage.

Note

If connecting to multiple connection chimneys and depending on country regulations, additional safety equipment is required. Your local chimney sweep will advise you in this case.

Note

Be sure to prevent condensed water from entering via the flue connection. For combination stoves, a condensate collection pipe must be used for ceiling connection or flue pipe connection at the top. Damages caused by condensate are excluded from manufacturer's warranty.

Connecting to a steel chimney

The connection must be calculated and shown with EN13384-1 and EN13384-2.

Use only insulated (double) stainless steel tubes (flexible aluminum or steel tubes are not permitted).

An inspection door for regular inspection and cleaning must be present.

The flue pipe connection to the chimney has to be air-tight.

Combustion air

Every combustion process requires oxygen from the surrounding air. This so-called combustion air is removed from the living area in the case of individual stoves without external air connections.

This air removed must be replaced in the living space. Very tightly sealed windows and doors in modern flats may mean that too little air replaces that used. The situation also becomes problematical due to additional venting in flats (e.g. in the kitchen or WC). If you cannot feed in external combustion air, then air the room several times a day to prevent negative pressure in the room or poor combustion.

Feeding in external combustion air

only for devices which are able to run in room-air independent operation.

- Combustion air must be fed to the stove from outside via a sealed pipe for operation independent of the room air. According to EnEV, it must be possible to shut off the combustion air pipe. The open/closed setting must be clearly recognisable.
- Connect at the air intake either a pipe \varnothing 125 mm for log wood and combi stoves, or \varnothing 50 mm or \varnothing 60 mm for pellet stoves. Fix it with a hose clamp (not included!). At pellet stoves with longer intake pipes than 1 m the diameter should be increased to 100 mm. (see RIKA range).
- To ensure sufficient air intake, the intake pipe should not exceed max. 4 metres and have max. 3 bends.
- If the line leads outside it must have a windbreak.
- In extreme cold pay attention to icing on the air intake opening (check).
- It is also possible to suction in combustion air directly from another sufficiently vented room (e.g. cellar).
- The combustion air pipe must be tightly connected (adhesive or cement) permanently to the air nozzles of the stove.
- If you do not use the stove for a long time, please close the combustion air intake to prevent the stove from moisture.

Note

Please note that problems may arise due to updrafts in the case of combustion air supply from an integrated chimney ventilation shaft. If the combustion air flowing downwards is heated it may rise and thus counter the chimney with a resistance which in turn reduces the negative pressure in the combustion chamber. The chimney manufacturer is to guarantee that the resistance for the combustion air is a maximum 2 Pa even in the least favourable operating state of the chimney.

If one or more of these conditions does NOT apply, the result is poor combustion in the stove and negative pressure in the installation room.

3. FIRE PROTECTION

Minimum distances

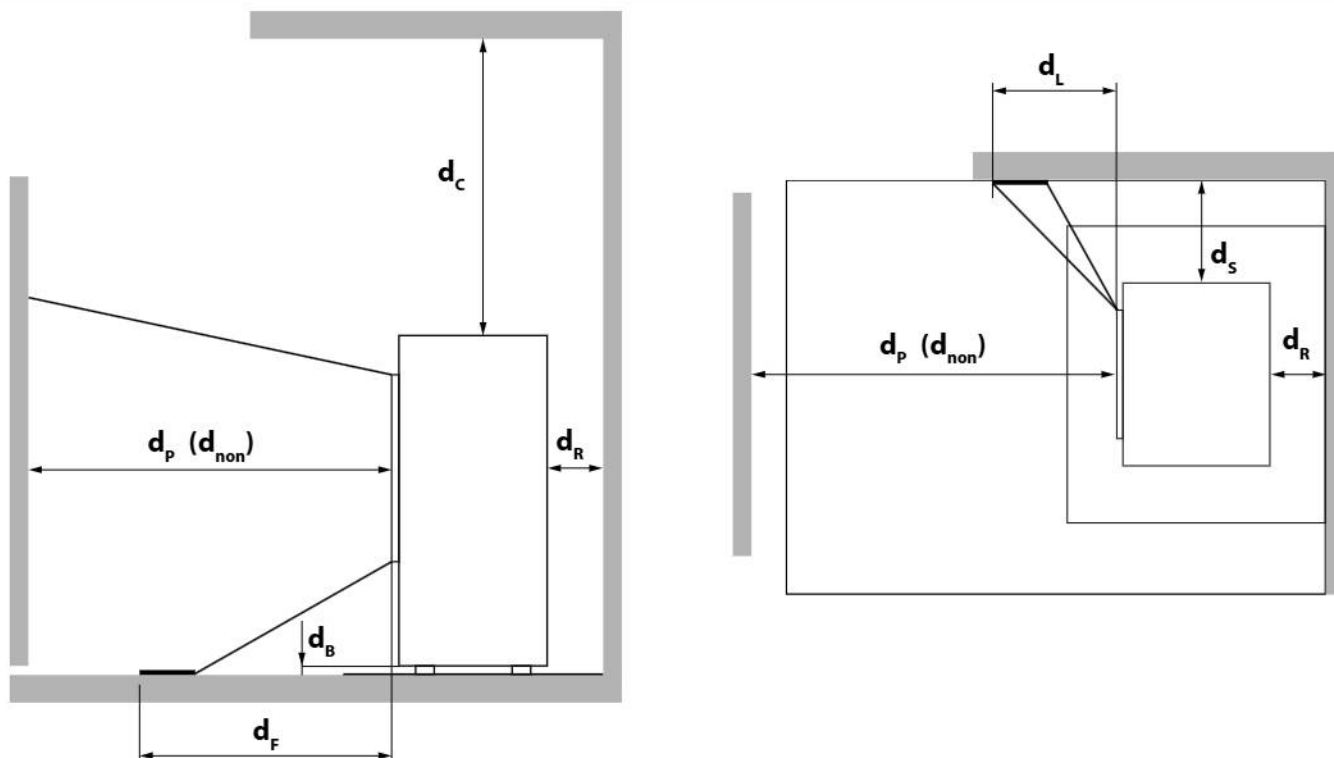

Minimum distance...

d_R	... from the back to combustible materials	[mm]	100
d_S	... from the sides to flammable materials	[mm]	100
d_C	... from the top to flammable materials in the ceiling	[mm]	500
d_P	... from the front to flammable materials	[mm]	800
d_F	... from the front to flammable materials in the lower front radiation area	[mm]	0
d_L	... from the front to flammable materials in the lateral front radiation area	[mm]	0
d_B	... below the floor (without feet) to combustible materials	[mm]	0
d_{non}	... to non-combustible walls	[mm]	400

Tip
For service and maintenance work, please keep a minimum distance of 20 cm to the side and behind the stove.



TO COMBUSTIBLE MATERIALS

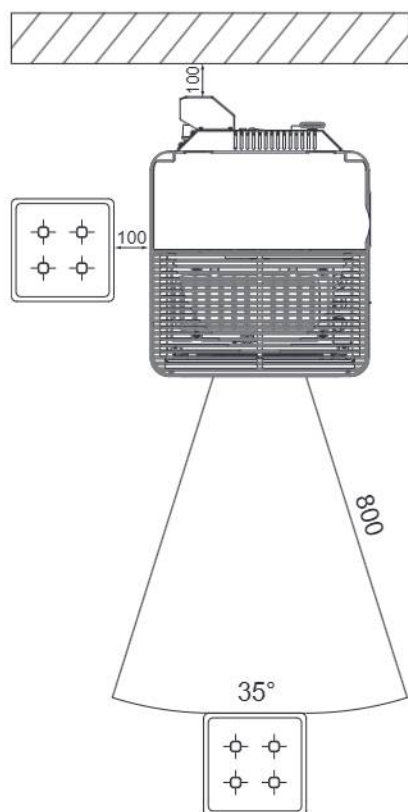

TO NON-COMBUSTIBLE MATERIALS

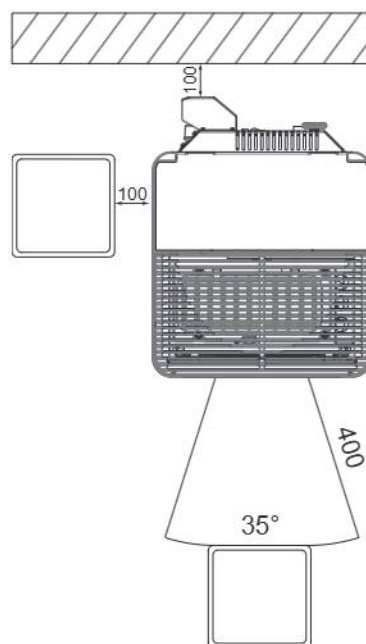

Floor protection

Combustible floors (wood, carpet, etc.) must be protected by a covering of non-combustible building materials (glass, sheet steel or ceramics). How this floor protection is to be implemented varies from country to country.

The maximum temperature at the bottom of your oven model does not exceed 60 °C above room temperature. This means that there cannot be an excessive increase in temperature in the lower area of the oven and it is not absolutely necessary to place a fireproof plate underneath. A shelf would therefore be sufficient.

Note

The country-specific regulations and ordinances must be observed!

Tip

If no state law deals with this topic, reference can be made to **ÖNORM B8311**:

Fireplaces must be placed on a support made of non-combustible materials on the floor. This must protrude at least 5 cm from the side of the fireplace and at least 30 cm on the operating side in front of the combustion chamber opening.

4. TECHNOLOGY AND SAFETY FUNCTIONS

The technological advances in your new combi stove are the result of years of testing and practical experience. The practical advantages of your pellet stove are convincing:

Operating comfort

All functions can be regulated using the integrated touch display. The user-friendly interface permits extremely easy operation.

Top efficiency - lowest emissions

All processes in the stove are fully automated. The parameters

- Air control
- Temperature monitoring
- Pellet dosing

are continuously optimised. This guarantees optimum combustion. The result are low consumption and very good exhaust gas values that even undercut the legally permitted limits.

Note

Due to the automated control, you may hear flame fluttering, falling pellets and sounds from the activation of the electronic components during operation.

DAR - Dynamic Air Regulation

Only for stoves with DAR

A differential pressure sensor in the supply air system measures the air flow. The fan speed is adjusted automatically and guarantees optimum combustion.

The air pipe of an external supply air pipe can also be monitored in this way.

Pressure monitoring

The negative pressure in the combustion chamber is continuously monitored during operation. Below a defined threshold, a correct operation can not be guaranteed and the unit will switch off with the fault message „NOT ENOUGH LOW PRESSURE“ for safety reason.

Note

If the stove is used in a habitation together with a kitchen hood or a ventilation (WC) it might happen that the built-in pressure switch stops the stove. If using the hood make sure that an adequate supply of air is ensured.

Low-temperature shutdown

The unit switches off if the stove cools below a minimum temperature. This switch-off may occur if pellet ignition is delayed.

Electrical excess current protection

The stove has a main fuse (at the rear) to protect against excess current.

Automatic cleaning cycle

The speed of the flue gas fan is increased every hour for a short period to blow ash from the burn pot, increasing the operational safety. The status indicator CLEAN appears on the display.

Only for stoves with turning grids:

Every 6 hours (interval adjustable) an additionally automatic big cleaning cycle is performed. The stove stops, the automatic cleaning tilts the grid and then re-ignites the stove. The status indicator BIG CLEAN appears on the display continuously. The cleaning procedure with tilting the grid is to convey ash and clinker from the burn pot into the ash drawer.

Note

This additional function does not replace a manual cleaning as described in CLEANING and MAINTENANCE, as this is absolutely necessary to do regularly.

Note

Due to the turning grid there is a certain generation of noise during the automatic cleaning cycle (START or BIG CLEAN).

Component monitoring

All the electrical components used are continuously monitored during operation. If a component is defective or can no longer be actuated correctly, then operation is stopped and a warning or error message is issued (see MANUAL TOUCH DISPLAY).

Auger motor monitoring

Too long or wet pellets as well as pellets with too high dust content (see BRIEF INFORMATION ON FUEL PELLETS) can cause so-called "auger jammers" in the auger channel. This may also happen if the pellets accumulate in the burn pot and the backlog reaches into the chute. The auger motor reacts in both cases with an increased current consumption, which causes the error message: DISCHARGE MOTOR BLOCKED. The stove will be stopped. Please call the customer service immediately.

Power failure (during heating)

After a brief power failure, the operating functions that were set before the power failure, continues. If the power failure lasts longer, the stove goes to start phase if sufficient temperature or embers are present. If the power failure lasts too long, the stove goes into the stop phase. The flue gas fan continues to burn any pellet residues (approximately 10 minutes). Then it will restart automatically.

Power failure (during the initial stage)

After a brief power failure the boot process continues. If the power failure lasts longer, the stove is in the stop phase. The flue gas fan continues to burn any pellet residues (approximately 10 minutes). Then it will restart automatically.

5. COMFORT OPTIONS

Room sensor, Radio room sensor

This option permits control of your stove via room temperature. You can set both the room temperature and the heating times required. A room temperature selected by you is observed during the heating times.

Please see the operating instructions for the option room sensor and wireless room sensor for more detailed information.

Interface for various options

for various options

The ROOM SENSOR and the WIRELESS ROOM SENSOR are to be connected to the interface (stove rear) using the connection cable supplied.

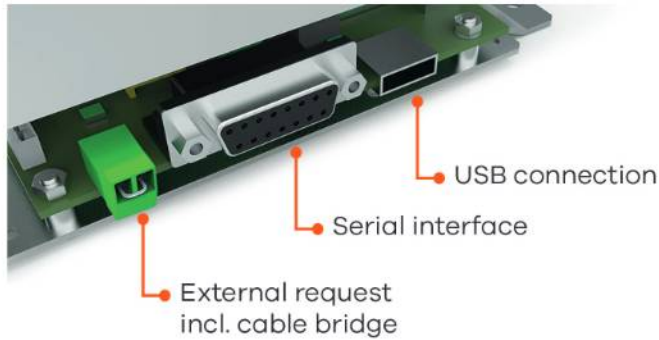

(condition as delivered)

External request

- Low-pressure controller* for multiple occupancy (e.g. BROKO - ON by default, see Settings)
- External room thermostat*, Rotary controller* (in conjunction with MULTIAIR)
- Contactor (e.g. exhaust hood)*

* remove cable bridge and connect a 2-pin cable with a section between 0.5 and 0.75mm² instead.

It will take approximately 1 minutes for your stove to shut down after receiving an external shut-down request.

Note
Operation is not possible unless either the cable bridge, or an external request (e.g. an external room thermostat) are connected. The external request has priority over all operating modes (MANUAL / AUTOMATIC / COMFORT).

Serial interface

- RIKA room sensor/ RIKA radio room sensor (available on request)
- RIKA GSM Control (available on request)

USB connection

- RIKA FIRENET (available on request)

External room thermostat

Your stove has an interface on the rear wall to which you can connect a customary room thermostat. This requires a 2-pole cable of 0.5 – 0.75 mm² cross-section that you have to connect instead of the cable bridge fitted for delivery.

External connection cable bridge

If the control of your stove is to be assumed by an external room thermostat, you have to connect your external room thermostat (1) instead of the standard integrated cable bridge (2).

The connected room thermostat can be operated in either MANUAL or AUTOMATIC MODE. In both MODES, the current set heat output is used, in AUTOMATIC MODE the heating times set at the stove can also be activated.

You can see whether the external demand is currently activated in the INFO main menu in submenu item Info - inputs.

If your stove receives an external demand to stop operation, it takes approx. 5 minutes until it switches off. All further settings required to your thermostat can be taken from the respective room thermostat operating instructions.

Note

Operation is not possible unless either a cable bridge or an external room thermostat is connected. The external demand has priority over all operating modes (MANUAL/AUTOMATIC/COMFORT).

Option RIKA FIRENET 2nd Generation

Only for combination and pellet stoves with touch panel version V229 or higher.

The FIRENET module connects your stove to the Internet. You can operate the stove with any Internet-enabled device (tablet, PC, Smartphone ...). So you retrieve the operational status, various information and make your settings remotely.

For further information, please contact your dealer.

RIKA VOICE

for combi and pellet stoves with touch display, version V2.26 or above, only and in combination with the RIKA Firenet module and Amazon Alexa

RIKA VOICE allows you to control your RIKA stove by simply speaking to it. Power on or off, switching between modes or adjusting the preferred heat output or room temperature: a few words is all it takes!

More detailed information could be obtained at www.rika.at or from your dealer.

6. BRIEF INFORMATION ON FUEL - PELLETS

What are pellets?

Wood pellets are a standardised fuel. Every manufacturer must adhere to certain conditions in order to enable flawless, energy-efficient heating. Pellets are made from wooden waste, from sawmills and planning workshops, as well as from residue from forestry operations. These starting products are crushed, dried, and pressed into pellet fuel without any bonding agent.

ENplus – Pellets

This ENplus standard sets benchmarks in the European pellet market. The traceability of pellets is ensured thanks to the use of identification numbers. The pellet manufacturers' production facilities and manufacturing processes are reviewed every year. A quality assurance system ensures the pellets comply with the requirements of the new standard and that the conditions for trouble-free heating are guaranteed.



Wood pellet specification according to ENplus – A1

Parameter	Measure	ENplus-A1
Diameter	mm	6 (±1) ²⁾
Length	mm	3,15–40 ³⁾
Buld density	kg/m ³	≥ 600
Calorific value	MJ/kg	≥ 16,5
Water content	Ma.-%	≤ 10
Fine fraction (< 3,15 mm)	Ma.-%	≤ 1
Mechanical rigidity	Ma.-%	≥ 97,5 ⁴⁾
Ash content	Ma.-% ¹⁾	≤ 0,7
Ash softening temperature	(DT) °C	≥ 1200
Chlorine content	Ma.-% ¹⁾	≤ 0,02
Sulphur content	Ma.-% ¹⁾	≤ 0,03
Nitrogen content	Ma.-% ¹⁾	≤ 0,3
Copper content	mg/kg ¹⁾	≤ 10
Chrome content	mg/kg ¹⁾	≤ 10
Arsenic content	mg/kg ¹⁾	≤ 1
Cadmium content	mg/kg ¹⁾	≤ 0,5
Mercury content	mg/kg ¹⁾	≤ 0,1
Lead content	mg/kg ¹⁾	≤ 10
Nickel content	mg/kg ¹⁾	≤ 10
Zinc content	mg/kg ¹⁾	≤ 100

1) in an anhydrous state

2) diameter must be specified

3) a maximum of 1% of the pellets may be longer than 40 mm, max. length is 45 mm

4) the limit value of ≥ 97,7 Ma.-% applies when conducting measurements with a lignotester (internal control)

Your pellet stove is only approved for the burning of pellets of tested quality. Please ask your pellet stove dealer for tested fuel and a list of monitored fuel manufacturers.

Note

Only burn pellets that have been inspected according to ENplus - A1. Using poor quality or prohibited pellet fuel will have a negative effect on the function of your pellet stove and can also lead to the warranty becoming null and void, as well as the product liability connected with this.

Note

The temperature and output of your stove may vary due to different pellet qualities.

Note

The delivery rate displayed for pellet consumption (INFO - PARAMETERS - FEED RATE TOTAL) may differ from the actual quantity due to the different quality and bulk density of the pellets. This does not constitute grounds for complaint.

Note

Burning straw, maize, woodchips etc. is not permitted! Observe waste incineration legislation! Non-observance of these regulations makes void all warranty and guarantee claims and may impair the safety of the unit!

Pellet container refilling during operation

Note

CAUTION when filling! Avoid direct contact between the plastic bag and the hot stove. Immediately remove all pellets that have fallen on the hot stove or next to the container!

We recommend always having a suitable amount of pellets in the container to prevent the fire from extinguishing due to a lack of fuel. Check the level frequently. However the container lid should be kept closed, except during filling.

If you refill the container during operation (open the container lid), the fan will speed up and the pellet auger will stop; operation will only be continued once the container lid is closed again.

Pellet container capacity: (see TECHNICAL DATA)

Pellet storage

In order to guarantee problem free burning of the wooden pellets, it is imperative necessary to store the fuel as dry as possible and free from impurities.

Pellets should not be kept in sacks outdoors or stored in a manner where they are exposed to the environment. This can lead to blockages in the screw conveyor.

Note

Screw stoppers are excluded from the warranty.

Amount of fuel

	Nominal Load	Part Load
Amount of fuel	~2,1 kg/h*	~0,6 kg/h*
Burn time at full pellet hopper (RAH / RAO / MULTIAIR)	~21 h* / ~14 h* / ~17 h*	~75 h* / ~50 h* / ~61 h*

*Practical values may vary depending on pellet quality.

Note

Pellet consumption depends on the size of the pellets. The larger the pellet, the slower the feed and vice versa.

Time-burning fireplace (INT)

Your stove corresponds to the INT type and is therefore a time-burning fireplace. This is intended for operation at short intervals over any period of time by successive filling.

Note

If the stove is heated in continuous operation, this results in increased wear, especially of the thermally stressed parts. The cleaning intervals may be shortened. It is therefore essential to observe the cleaning and maintenance instructions!

7. INSTRUCTIONS FOR COMMISSIONING PROTOCOL

Operator instruction

This is one of the most important points in the putting into operation. The following points must be clearly communicated to the operator by an authorised service technician:

Stove functions

- Explanation of the processes in the stove during ignition, normal operation, cleaning phase etc.

Control

- Refilling the pellet container
- Functions and settings
- Options / Accessories
- Programming heating times

Operating Instructions

- Handover and reference to the content of the following points

Warranty terms

- Difference between warranty (statutory) and guarantee (voluntary)
- Terms of guarantee
- Determination of wearing parts
- Reference to pellet quality to be used and the consequences of poor quality

Cleaning Instructions

- Regular cleaning is necessary for regular heating operation
- The ash drawer is to be emptied regularly
- The flue gas pipes are to be cleaned once or twice in the heating season depending on stove type; by a specialist company is best

Note

We recommend at least once a year to have all maintenance carried out by your RIKA dealer.

Combustion

- All doors must close tightly to prevent intake of false air



COMMISSIONING REPORT

for RIKA pellet and combi stoves.

Installation address

Surname, forename

Street, number

Post-code, city

E-mail, phone

RIKA retailer

Retailer stamp

Device data

Device type

Serial number

Cladding undamaged? YES NO

Software version

Display version

Year of production

Electrical peripherals

Connection socket grounded

Room thermostat Model

FIRENET Model

GSM modem Function checked

Phone provider

Inspection of system and safety components

Smooth operation of flues gas flap checked (combi stove)

Smooth operation of backfire safety flap checked (combi stove)

Differential pressure sensor (building) YES NO

Fire alarm in place? YES NO

Fire-proof floor covering in place? YES NO

Other

Installation

Proper Installation according to Installation and user manuals YES NO

Comments

Room height

Room ventilation YES NO

Exhaust hood (outdoor connection) YES NO

WC extraction YES NO

8. OPTIONAL CONNECTION

Note

Only work on the unit when the mains plug has been disconnected and the stove has cooled down completely.

Note

During assembly / dismantling do not allow objects (screws etc.) to fall into the pellet container – they can block the screw conveyor and damage the stove.

Note

During any conversion work, take particular care of your fingers and any panels and stove attachments. Select soft bases to prevent scratches to your living space furniture and stove panels.

Changing the connection to the left side

Open the pellet hopper lid.

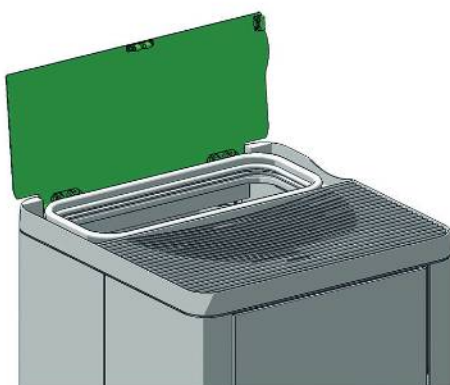

Open the decorative glass door. Remove the convection fins by lifting them straight up.

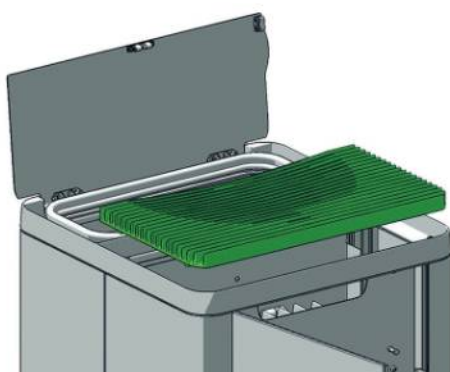

Remove the two screws and remove the left rear side panel.

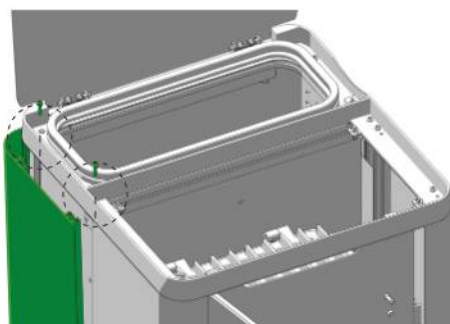

Mount the cover plate at the cutout to the back wall.



Place the 90 degree elbow with cleaning lid (not included, RIKA standard flue pipe) on the flue outlet. Make sure that everything is tight!

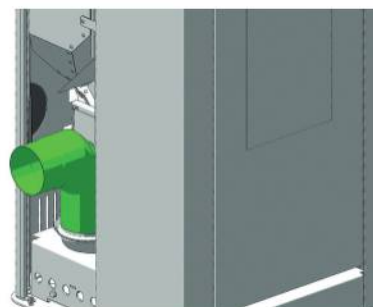

Place the side panel for the bottom side connection into the recesses and screw it at the top.

Install the removed parts in reverse order.

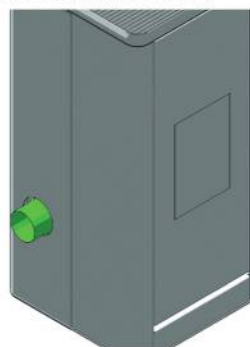

9. MAINTENANCE

The frequency with which the stove requires cleaning and the maintenance intervals depend on the fuel you use. High moisture content, ash, dust and chips may more than double the maintenance required. We would like to point out again that only tested and recommended pellets may be used as fuel.

Note

Ash may contain embers – only place ash in sheet steel containers. FIRE RISK! In a cold state, dispose it of in the household waste.

Note

We recommend at least once a year to have all maintenance carried out by your RIKA dealer.

Open the combustion chamber door

To open or close the combustion chamber door and the door of the ash-chamber use the included key. This key can be stored on the back of the stove when not in use.

Cleaning the fire trough

If necessary, but at least 1x a week

Despite the automatic ash dumping prior to and during heating operation you have to remove ash or clinker from the combustion chamber, from the fire trough and the turning grid regularly.

Use the cleaning function to put the grid vertical.



Remove the clinker using the brush supplied and sweep the ashes with a broom in the ash tray. Vacuum out the fire trough.

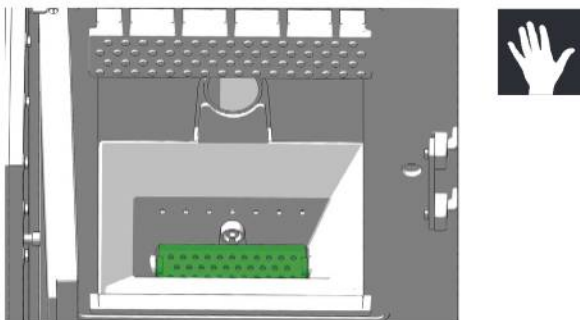

Do not damage the ignition when cleaning with a brush. Vacuum out the pipe of the ignition.

Note

Clean the fire trough regularly. Only clean when cold, when embers are extinguished!

Cleaning the flame temperature sensor

Remove the dust deposits from the sensor at regular intervals. Use a clean cleaning cloth or newspaper.

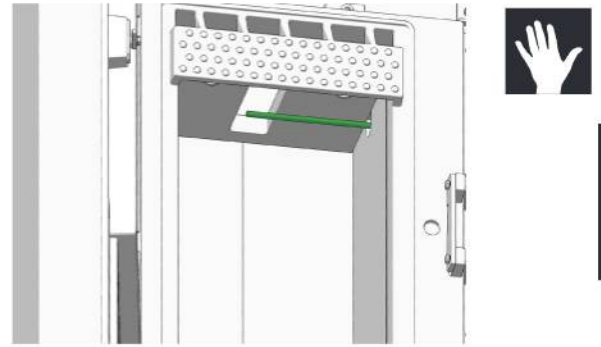

Empty the ash drawer

Empty the ash drawer regularly. The ash drawer is simply pulled forward with ash-chamber door open.

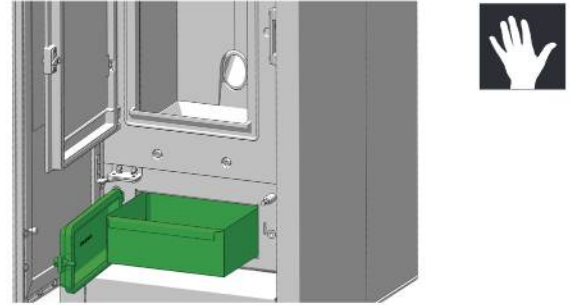

Cleaning the door glass

The viewing window becomes coated in the case of solid fuels, particularly with the very fine ash of wood pellets, light or dark depending on the pellet quality (especially with low output). The glass can be cleaned best with a moist cloth. Stubborn dirt can be removed with a special cleaner available from your stove dealer.

Cleaning painted surfaces

Wipe the painted surfaces with a damp cloth, do not scrub. Do not use solvent-containing cleaners.

10. CLEANING

Depending on pellet consumption, a message prompting cleaning of the stove appears on the display in regular intervals. This message can be acknowledged on the Touch Display, while continuing operation. Perform a cleaning cycle at the next opportunity.

Subsequently, reset the counter in the SETTINGS menu / RESETS submenu, as per operating instructions of TOUCH DISPLAY.

Tip

The message will only stop reappearing once you have reset the feed volume in the SETTINGS / Resets menu.

Note

Your stove must be switched off and cooled before any maintenance work is performed. Only work on the unit when the mains plug has been disconnected.

Cleaning the convection air openings

Vacuum clean any dust deposits from the convection air openings at regular intervals.

The stove should be cleaned thoroughly prior to the start of the heating season to prevent excess odour.

Note

To prevent your stove from overheating of the internal components, do never cover the convection fins!

Combustion air - intake

If necessary, please also clean the air intake with a Hoover.

Note

Only when the stove is cold! You could vacuum out embers – FIRE RISK!

Cleaning the pellet container

Do not refill the completely empty container immediately; remove the residues (dust, chippings etc.) from the empty container. The unit must be disconnected from the mains!

Cleaning the flue pipes

(annually)

Remove the flue pipes. Inspect and clean the chimney connection. Brush off any soot and dust deposits in the fire and in the flue pipes and vacuum.

Note

Accumulated fly ash in the flue gas channels may impair the performance of the stove and pose a safety risk.

Bearings

(annually)

All built-in bearings (pellet screw, turning grid) should be checked. Clean or replace bearings depending on condition.

Checking door seal

(annually)

The condition of the seals at doors and glass should be checked at least once a year. Repair or replace seals depending on condition.

Note

Only intact seals ensure your stove works perfectly!

Cleaning the flue gas channels and flue gas collecting duct

The flues are situated under and behind the combustion chamber.

Note

Only work on the unit when the mains plug has been disconnected and the stove has cooled completely.

Note

During assembly / dismantling do not allow objects (screws etc.) to fall into the pellet container – they can block the screw conveyor and damage the stove.

Note

During any conversion work, take particular care of your fingers and any panels and stove attachments. Select soft bases to prevent scratches to your living space furniture and stove panels.

Open the pellet container lid.

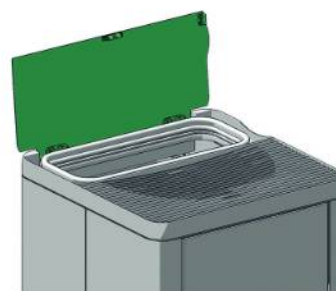

Open the decorative glass door. Remove the convection fins by lifting them straight up.

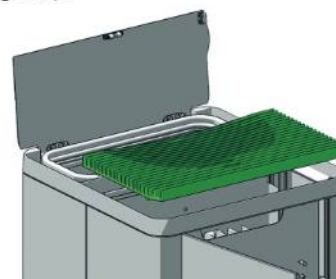

Loosen the wing nut on the lid of the cleaning opening, tilting the eyescrew forwards. Open the lid. When cleaning the stove, be sure to either keep the cleaning lid open or to laterally pull it out from its hinges to remove it.

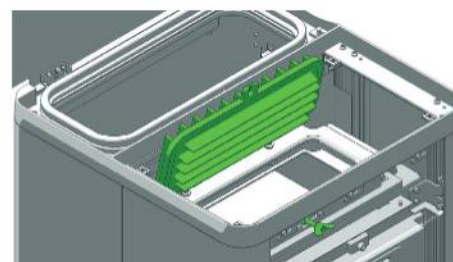
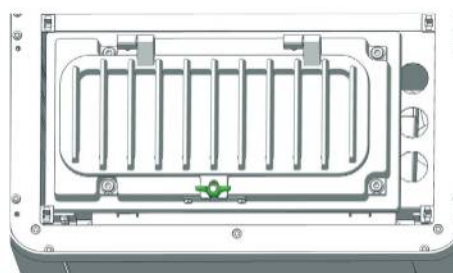

Note

Please mind your fingers! They could be injured by the lid falling down.

Lift the top baffle plate, displacing it sideways. It will tilt down so you can remove the plate. Vacuum the combustion residues off the baffles with a vacuum cleaner.

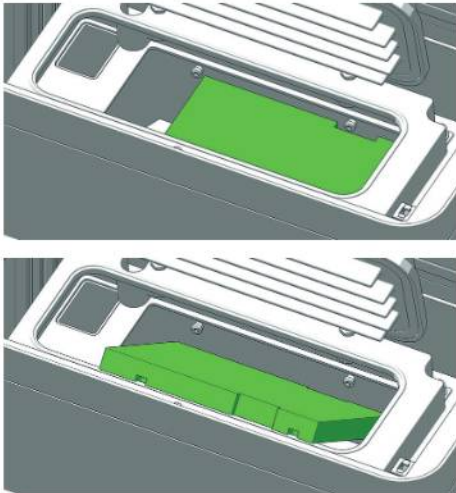

Now clean the lateral flues with the supplied brush.

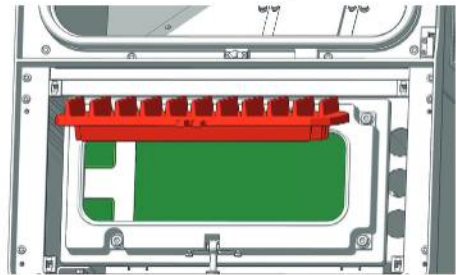

Remove the ash tray.

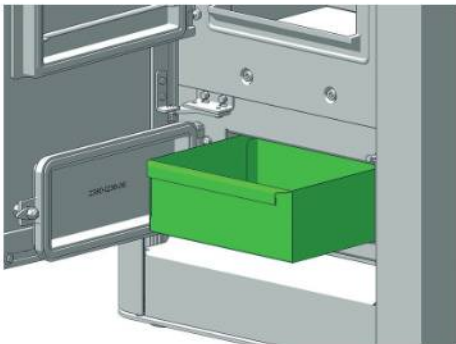

Open the 4 wing nuts and remove the cleaning lid.

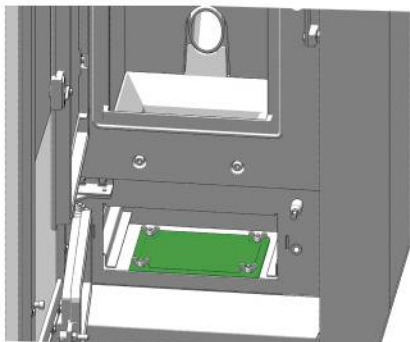

Vacuum-clean the combustion residues off the flue gas collecting duct, especially the areas to the side flues.

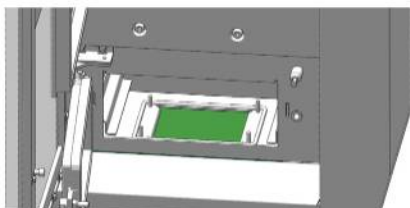

Loosen the two screws and remove the rear side panel.

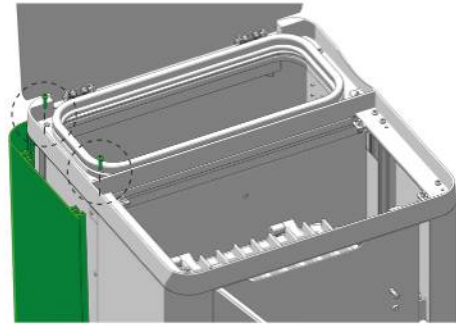

Loosen the screw of the cleaning lid a little bit and slide the lid. You can lift it and vacuum the combustion residues with a vacuum cleaner.

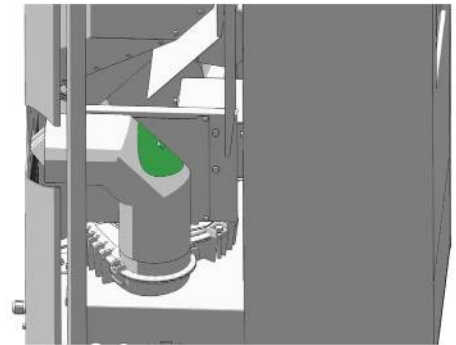

Note

For the indispensable cleaning concerning Sumo RAO and Filo RAO the application of the interceptor for ashes is strongly recommended.



Model Sumo RAO (option Interceptor for ashes) : Open the knurled nuts of the cleaning lid. Remove and empty the ashtray. Vacuum the combustion residues from the interceptor for ashes. Vacuum the case from the induced draft fan as well.

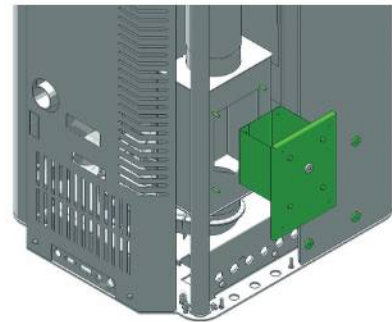

Install the removed parts in reverse order again.

Note

Your stove may suck in false air via incorrectly sealed cleaning covers; this air may lead to incomplete combustion in the fire trough and thus piling up of pellets. DANGER of FIRE!



To ensure the proper operation of your pellet stove, replace any defect (porous, frayed) seals after cleaning and maintenance.

11. PROBLEMS - POSSIBLE SOLUTIONS

Problem 1

Fire burns with weak, orange flame. Pellets heap up in fire trough, window soots up.

Cause(s)

- Insufficient combustion air
- Poor chimney draught
- Stove is sooted over inside

Possible solutions

- Remove any ash or clinker from the fire trough that may block the air inlets. (see CLEANING/MAINTENANCE)
- If possible swap to better pellet quality.
- Check whether flue gas pipes are blocked with ash (see CLEANING/MAINTENANCE).
- Check whether the air intake or flue tubes are blocked.
- Check door and cleaning cover seals for leaks (see CLEANING/MAINTENANCE)
- Clean fan (see CLEANING/MAINTENANCE)
- Have service performed by authorised specialist company.
- The window has to be cleaned from time to time (see CLEANING/MAINTENANCE)

Problem 2

Stove smells strongly and smokes outside.

Cause(s)

- Burning-in phase (taking into service)
- Stove has accumulated dust and/or dirt

Possible solutions

- Wait to end of burning-in phase and vent the room sufficiently.
- Vacuum off any dust deposits from the convection air openings at regular intervals

Problem 3

Flue gas discharge when wood is added and during heating phase.

Cause(s)

- Leaking cleaning openings
- Chimney draught too low
- Leaking flue pipe connection

Possible solutions

- Check seals and replace (fire door, cleaning lid, ..)
- Check for blockages in the chimney
- Check connections and if necessary re-seal

Note

Please note that checks on the control system and wiring may only be performed in unit switched dead. Any repairs may only be performed by trained specialists.



Tip

If a malfunction message occurs, the cause must first be remedied; the unit can be put back into operation by acknowledging the malfunction at the internal unit.



12. TECHNICAL DATA



TECHNICAL DOCUMENTATION

according to commission regulation

(EU) 2015/1185 und 2015/1186

Ecodesign

Contact details of the manufacturer

Manufacturer:	RIKA Innovative Ofentechnik GmbH
Contact:	Andreas Bloderer
Address:	Müllerviertel 20 4563 Micheldorf Austria

Details of the device

Model Identifier:	SUMO (RAO / MA)
Equivalent models:	-
Notified body:	Technische Universität Wien, Getreidemarkt 9/166, 1060 Wien, Austria
Notified body no.:	1746
Test report no.:	PL-25026-04-P
Applied harmonised standards:	EN16510-1-2022; EN 16510-2-6:2022
Other applied standards/technical specifications:	-
Indirect heating functionality:	No
Direct heat output:	9,0
Indirect heat output:	-

Characteristics when operating with the preferred fuel

Seasonal space heating energy efficiency η_{s} :	80%
Seasonal space heating energy efficiency RIKATRONIC η_{s} :	-
Energy Efficiency Index:	121
Energy Efficiency Index RIKATRONIC:	-

Special precautions for assembly, installation or maintenance

<p>Fire protection and safety distances such as distances to combustible building materials must be observed!</p> <p>An adequate supply of combustion air for the appliance must be guaranteed at all times. Air-suction systems can interfere with the combustion air supply!</p> <p>The flue gas values of the appliance must be observed for the chimney dimensioning!</p>

Characteristics when operating exclusively with the preferred fuel

Heat output			
Nominal heat output	P_{nom}	9,0	kW
Minimum heat output	P_{min}	2,7	kW
Useful efficiency			
Useful efficiency at nominal heat output	$\eta_{th, nom}$	90,8	%
Useful efficiency at minimum heat output	$\eta_{th, min}$	96,3	%
Auxiliary electricity consumption			
At nominal heat output	e_{max}^e	0,015	kW
At minimum heat output	e_{min}^e	0,014	kW
In standby mode	e_{std}^e	0,004	kW
Permanent pilot flame power requirement			
Pilot flame power requirement	P_{pilot}	NPD	kW

Type of heat output/room temperature control	
single stage heat output, no room temperature control	Yes
two or more manual stages, no room temperature control (**)	No
with mechanic thermostat room temperature control (**)	No
with electronic room temperature control (**)	No
with electronic room temperature control plus day timer (**)	No
with electronic room temperature control plus week timer (**)	No
Room temperature control with presence detection (**)	No
Room temperature control with open window detection (**)	No
with remote control options (**)	No

Details of the fuel

Fuel	Preferred fuel:	Other suitable fuel:	η_s [%]	Space heating emissions at nominal heat output (*)				Space heating emissions at minimum heat output (**)			
				PM	OGC	CO	NO _x	PM	OGC	CO	NO _x
				mg/Nm ³ (13% O ₂)				mg/Nm ³ (13% O ₂)			
Wood logs, moisture content ≤ 25 %	No	No	-	-	-	-	-	-	-	-	-
Wood logs RIKATRONIC, moisture content ≤ 25 %	No	No	-	-	-	-	-	-	-	-	-
Compressed wood, moisture content < 12 %	Yes	No	80,0	13	2	31	123	26	5	188	57
Other woody biomass	No	No	-	-	-	-	-	-	-	-	-
Non-woody biomass	No	No	-	-	-	-	-	-	-	-	-
Anthracite and dry steam coal	No	No	-	-	-	-	-	-	-	-	-
Hard coke	No	No	-	-	-	-	-	-	-	-	-
Low temperature coke	No	No	-	-	-	-	-	-	-	-	-
Bituminous coal	No	No	-	-	-	-	-	-	-	-	-
Lignite briquettes	No	No	-	-	-	-	-	-	-	-	-
Peat briquettes	No	No	-	-	-	-	-	-	-	-	-
Blended fossil fuel briquettes	No	No	-	-	-	-	-	-	-	-	-
Other fossil fuel	No	No	-	-	-	-	-	-	-	-	-
Blended biomass and fossil fuel briquettes	No	No	-	-	-	-	-	-	-	-	-
Other blend of biomass and solid fuel	No	No	-	-	-	-	-	-	-	-	-

(*) PM = dust, OGC = gaseous organic compounds, CO = carbon monoxide, NO_x = nitrous gases

(**) Only required when applying correction factors F(2) or F(3)

Signed for and on behalf of the manufacturer by:
Andreas Bloderer / product management

RIKA[®]

Innovative Ofentechnik GmbH
A-4563 Micheldorf, Müllerviertel 20
Tel.: +43 (0)7582/686-14, Fax DW -43
www.rika.at

Andreas Bloderer

Micheldorf, 31.10.2025

In case of doubt as well as missing or incorrect translations, the German version is the only valid one.
Subject to technical and visual changes as well as layout and printing errors.

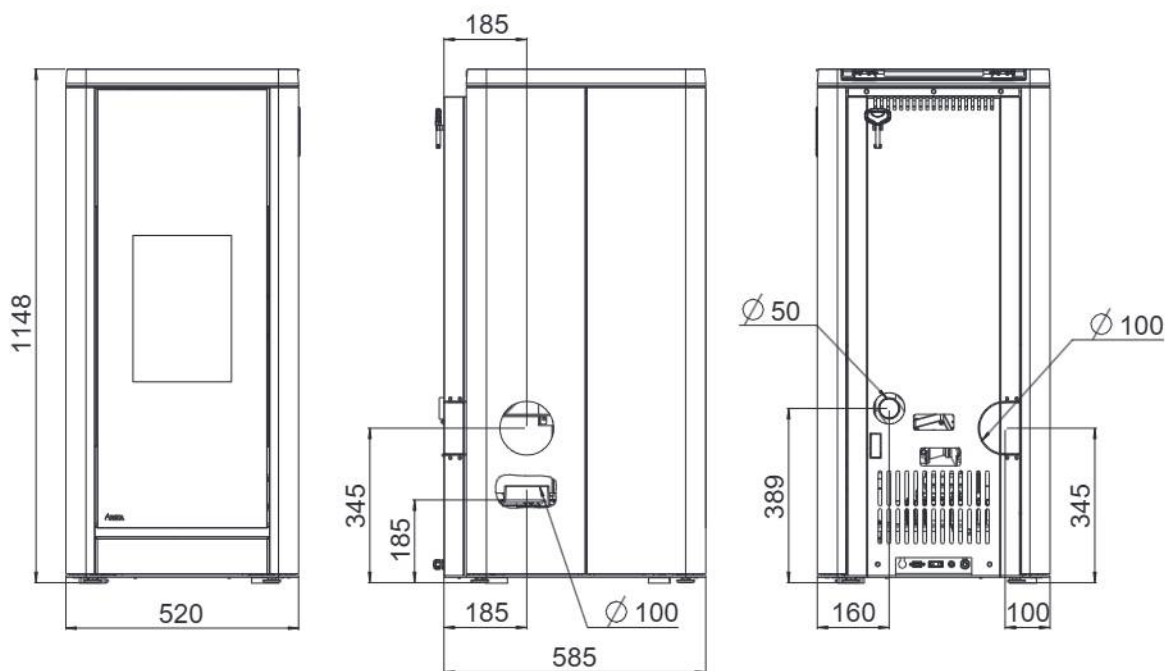

Dimensions

H	Height	[mm]	1148
L	Length	[mm]	585
W	Width	[mm]	520

Weight

m1	Mass of fireplace without steel panelling	[kg]	~ 170
m2	Mass of fireplace with steel panelling / with stone panelling	[kg]	~ 180 / ~195
m_{chim}	Maximum load through the chimney	[kg]	-

Flue pipe connection

d_{out}	Diametre of the flue gas connection	[mm]	100
	Top connection Connection height	[mm]	-
	Depth from rear wall to middle of flue pipe	[mm]	-
	Side distance	[mm]	-
	Rear connection height	[mm]	345
	Rear connection side distance	[mm]	100
	Side connection connection height	[mm]	345
	Depth to lateral connection	[mm]	185

Fresh air connection

	Diameter	[mm]	50
	Connection height	[mm]	389
	Lateral distance	[mm]	160
	Floor connection side distance	[mm]	-
	Floor connection depth	[mm]	-

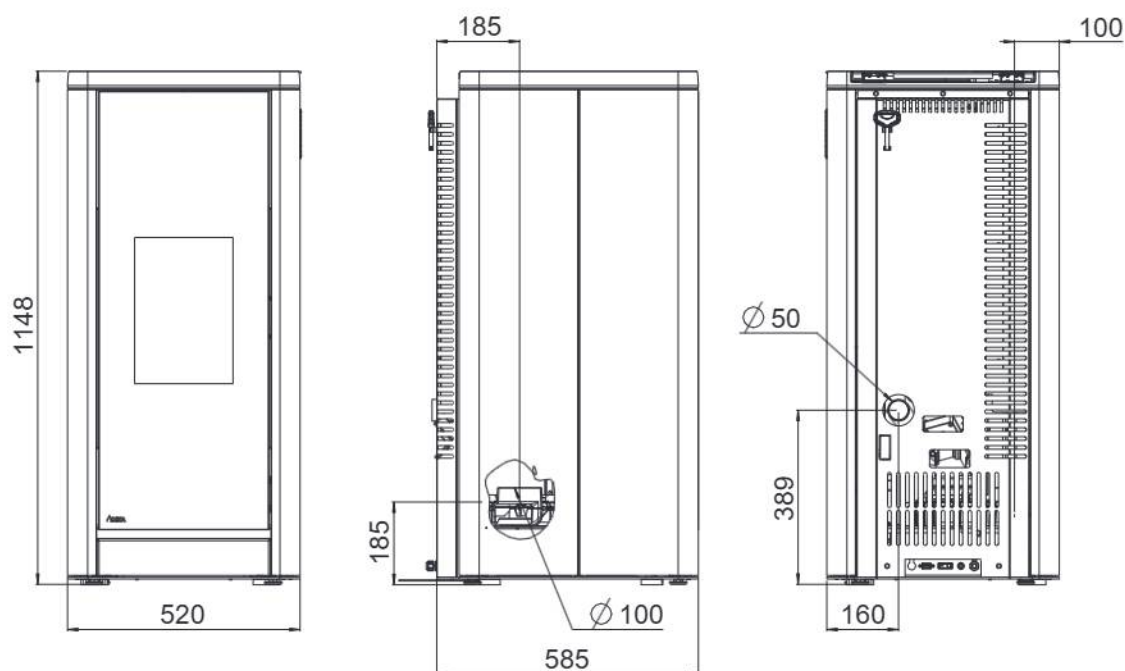

Dimensions

H	Height	[mm]	1148
L	Length	[mm]	585
W	Width	[mm]	520

Weight

m1	Mass of fireplace without steel panelling	[kg]	~ 170
m2	Mass of fireplace with steel panelling / with stone panelling	[kg]	~ 180 / ~195
m_{chim}	Maximum load through the chimney	[kg]	-

Flue pipe connection

d_{out}	Diametre of the flue gas connection	[mm]	100
	Top connection Connection height	[mm]	185
	Depth from rear wall to middle of flue pipe	[mm]	185
	Side distance	[mm]	100
	Rear connection height	[mm]	-
	Rear connection side distance	[mm]	-
	Side connection connection height	[mm]	-
	Depth to lateral connection	[mm]	-

Fresh air connection

	Diameter	[mm]	50
	Connection height	[mm]	389
	Lateral distance	[mm]	160
	Floor connection side distance	[mm]	-
	Floor connection depth	[mm]	-

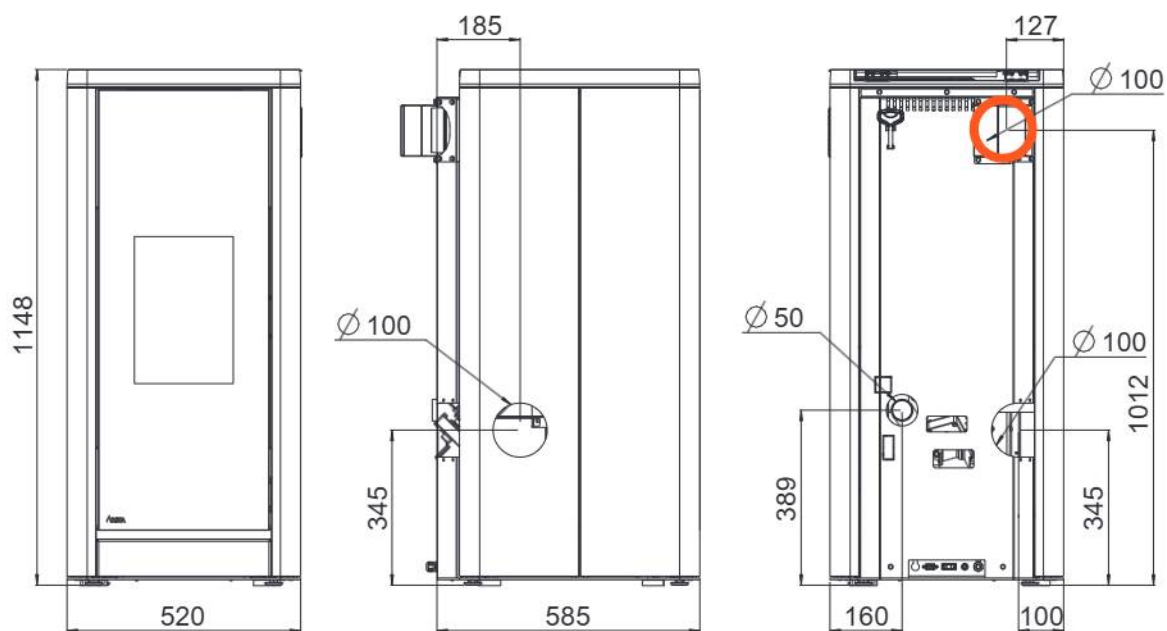

Dimensions

H	Height	[mm]	1148
L	Length	[mm]	585
W	Width	[mm]	520

Weight

m1	Mass of fireplace without steel panelling	[kg]	~ 170
m2	Mass of fireplace with steel panelling / with stone panelling	[kg]	~ 180 / ~195
m_{chim}	Maximum load through the chimney	[kg]	-

Flue pipe connection

d_{out}	Diametre of the flue gas connection	[mm]	100
	Top connection Connection height	[mm]	-
	Depth from rear wall to middle of flue pipe	[mm]	-
	Side distance	[mm]	-
	Rear connection height	[mm]	345
	Rear connection side distance	[mm]	100
	Side connection connection height	[mm]	345
	Depth to lateral connection	[mm]	185

Fresh air connection

	Diameter	[mm]	50
	Connection height	[mm]	389
	Lateral distance	[mm]	160
	Floor connection side distance	[mm]	-
	Floor connection depth	[mm]	-

Convection air connection MULTIAIR

	Diameter	[mm]	100
	Connection height	[mm]	1012
	Lateral distance	[mm]	127

General			
P_{nom}	Nominal heat output	[kW]	9
P_{SHnom}	Nominal room heat output	[kW]	9
P_{part}	Partial load heat output	[kW]	2,7
P_{SHpart}	Partial load room heat output	[kW]	2,7
	Fresh air requirement	[m ³ /h]	20
	MULTIAIR-Output*	[kW]	1,0 - 2,5
	MULTIAIR-Air volume*	[m ³ /h]	65 - 95
	Space heating capacity depending on the house insulation	[m ³]	50 - 240
η_{nom}	Efficiency at nominal heat output	[%]	90,8
η_{part}	Efficiency at partial load heat output	[%]	96,3
	Fuel consumption	[kg/h]	0,6 - 2,1
	Pellet container capacity**	[l]/[kg]	RAH: 69/~45 RAO: 46/~30 MA: 56/~37
	CO ₂ content	[%]	12,5
CO_{nom}	CO-Emission at nominal heat output with an oxygen content of 13% O ₂	[mg/m _N ³]	31
CO_{part}	CO-Emission at partial load heat output with an oxygen content of 13% O ₂	[mg/m _N ³]	188
NO_{xnom}	NO _x -Emission at nominal heat output with an oxygen content of 13% O ₂	[mg/m _N ³]	123
NO_{xpart}	NO _x -Emission at partial load heat output with an oxygen content of 13% O ₂	[mg/m _N ³]	57
OGC_{nom}	Hydrocarbon emission at nominal heat output with an oxygen content of 13% O ₂	[mg/m _N ³]	2
OGC_{part}	Hydrocarbon emission at partial load heat output with an oxygen content of 13% O ₂	[mg/m _N ³]	5
PM_{nom}	Dust Emission at nominal heat output with an oxygen content of 13% O ₂	[mg/m _N ³]	13
PM_{part}	Dust Emission at partial load heat output with an oxygen content of 13% O ₂	[mg/m _N ³]	26
$\phi_{f,g nom}$	Flue gas mass flow at nominal heat output	[g/s]	5,7
$\phi_{f,g part}$	Flue gas mass flow rate at partial load heat output	[g/s]	2
T_{snom}	Flue gas temperature at the flue gas connection at nominal heat output	[°C]	171
T_{spart}	Flue gas temperature at the flue gas connection at partial load heat output	[°C]	68
P_{nom}	Minimum conveying pressure at nominal heat output	[Pa]	12
P_{part}	Minimum delivery pressure at partial load heat output	[Pa]	10
P_{min}	Minimum supply pressure for chimney calculation	[Pa]	3
V_h	Space heat loss when the fireplace is not in operation	[m ³ /h]	-
η_s	Annual space heating utilisation factor	[%]	80
EEL	Energy Efficiency Index		121
E, f	Supply voltage, frequency	[V]/[Hz]	230/50
W_{max}	Maximum electrical power consumption	[W]	150
W_B	Average electrical power consumption	[W]	20
	Fuse	[A]	2,5
eI_{SB}	Consumption of electrical auxiliary energy in standby mode	[kW]	0,015
eI_{max}	Consumption of electrical auxiliary energy at nominal heat output	[kW]	0,014
eI_{min}	Consumption of electrical auxiliary energy at partial load heat output	[kW]	0,004
INT	Time-burning operation		
$T-Klasse$	Chimney designation		T200G

*with a two meter MULTIAIR line in combination with RIKA design outlet, values may differ in practice.

**Capacity in kg may vary due to different pellet bulk densities

Note

The criterion for the end of the test cycle for pellet stoves is 3 hours.
For log wood stoves, the CO₂ criterion is 4%.

Spare parts overview Exploded view - SUMO / SUMO RAO

Note

Only original parts supplied by the manufacturer may be used.

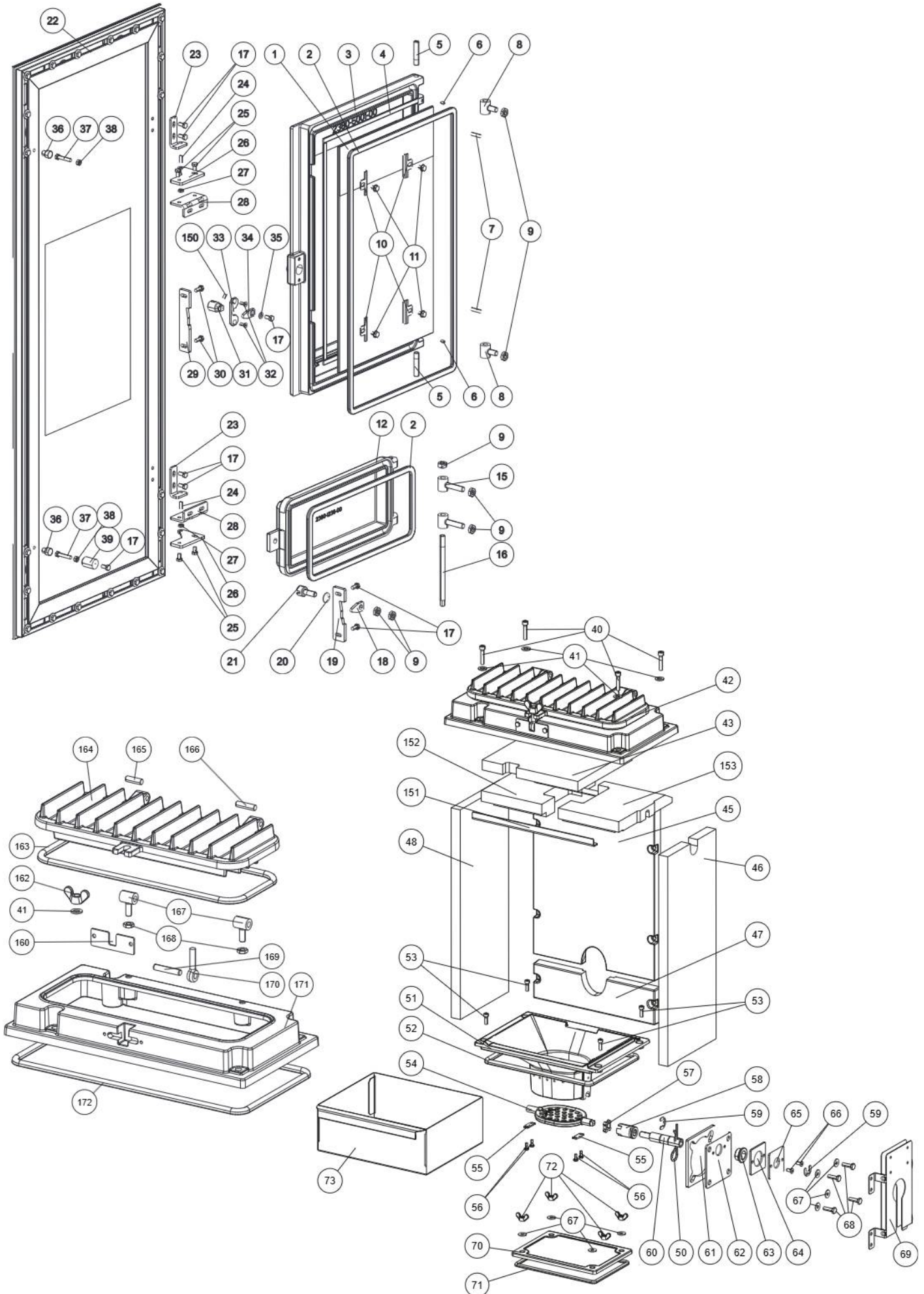

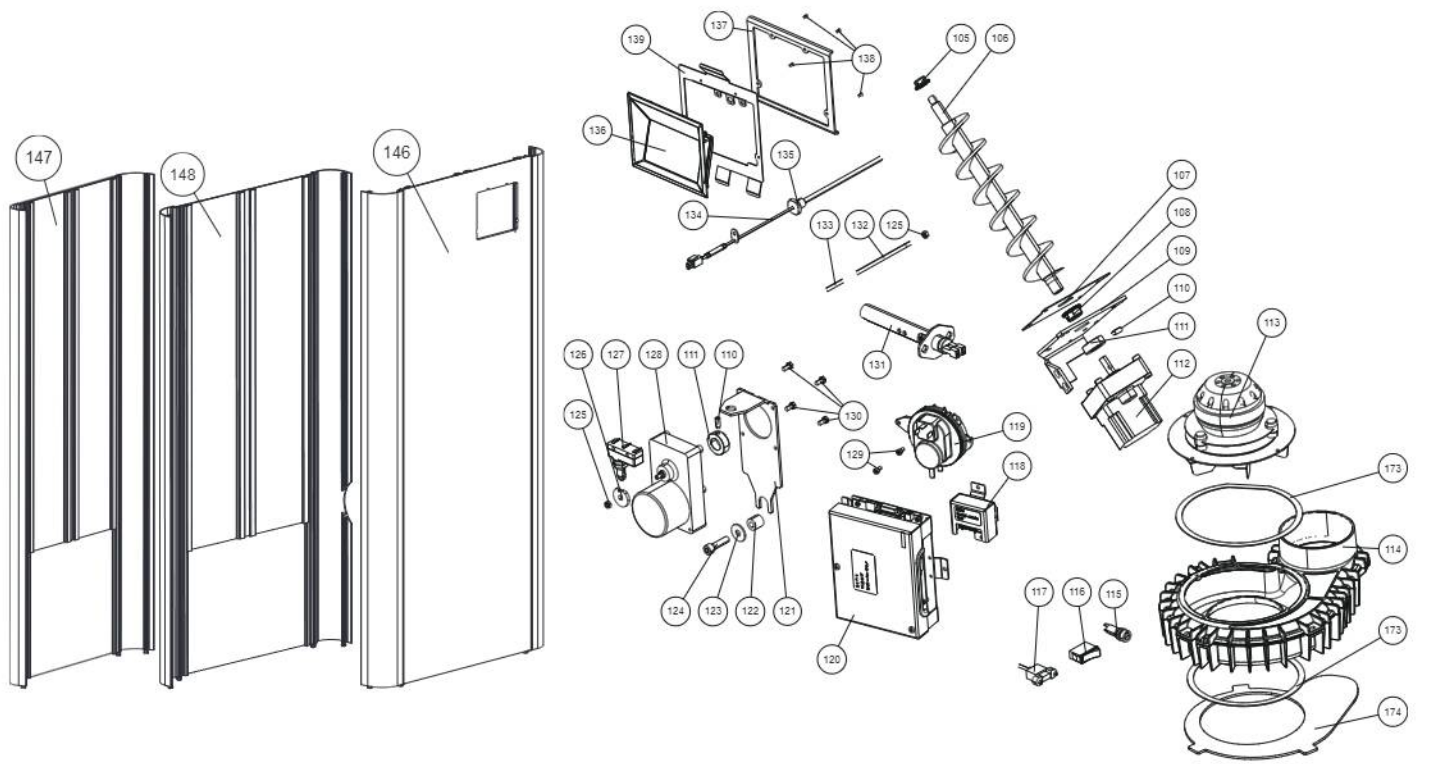
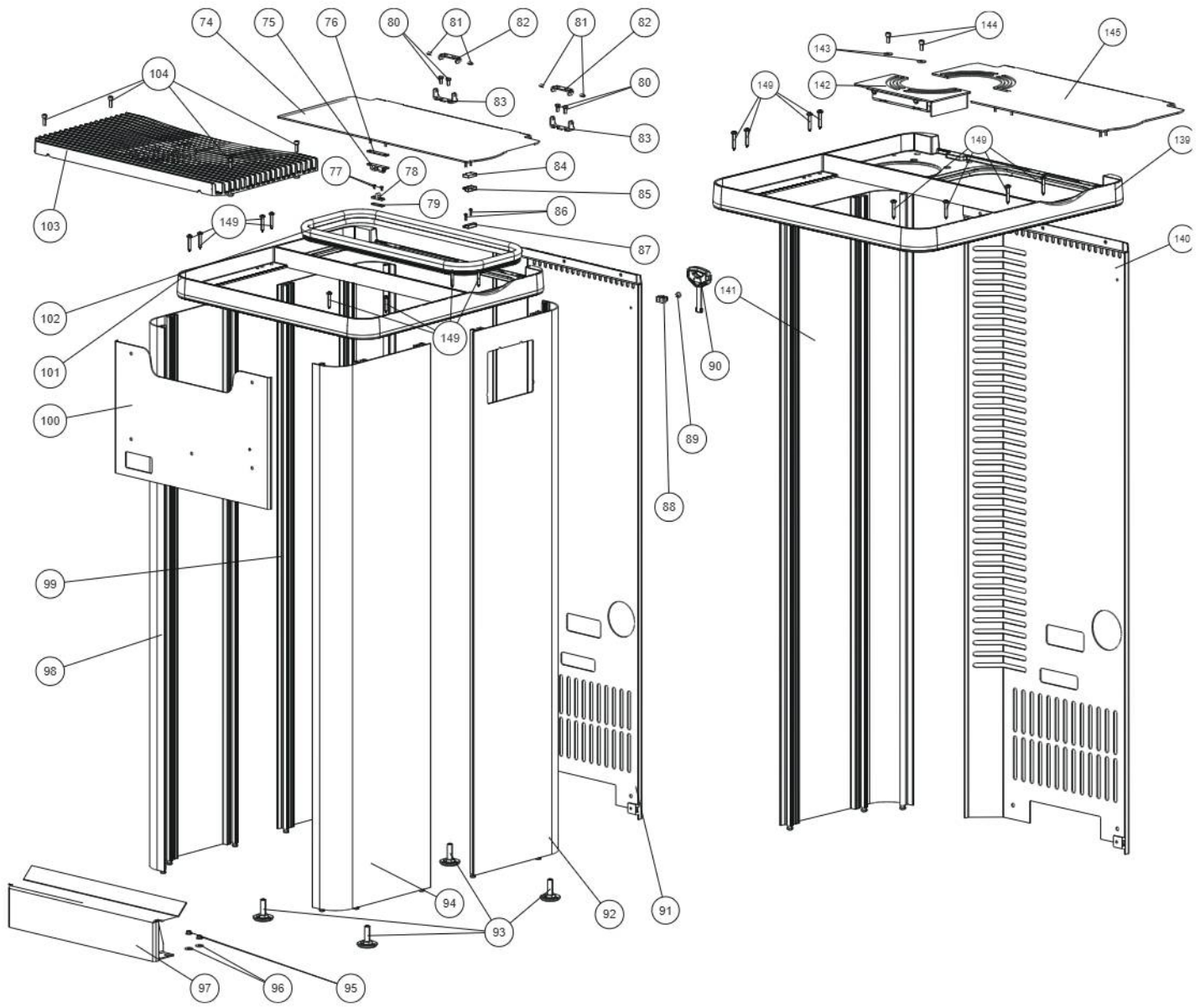

Spare part overview article numbers - SUMO / SUMO RAO

Nr.	Art.Nr.	Description	Nr.	Art.Nr.	Description
1	Z37257	Front door glass	56	N112148	Hexagonal screw M04X10
2	N112551	Round sealing strip grey D11 (1m)	57	L02675	Catch plate
3	Z35727	Combustion chamber door	58	Z36165	Intermediate shaft
4	N103693	Flat seal black 8x2	59	N112125	Circlips
5	N112181	Headless screw M08X40	60	Z35950	Drive shaft turning grid
6	N112182	Grub screw	61	Z35951	Seal bearing
7	N111637	Setscrew door opener M05X20	62	Z36934	Bearing holder plate
8	B17524	Hinge black	63	N102688	Sinter bearing ID16
9	N105378	Hexagonal nut	64	Z36933	Intermediary
10	L00475	Glass holder	65	L02686	Holder plate
11	N107488	Hexagonal screw M05x08	66	N108485	Allen screw M05X10
12	Z35725	Cleaning opening	67	N112009	Flat washer
15	B15396	Hinge	68	N111968	Hexagonal screw M06
16	Z35923	Hinge shaft	69	LBO0625	Heat protection assy
17	N111950	Hexagonal screw M05x10	70	Z35451	Cleaning opening
18	L02713	Fastener tongue	71	N103066	Round sealing strip black D06
19	L02712	Closure flap	72	N112077	Wing nut
20	N100699	Disc spring	73	L02659	Ash drawer
21	Z35924	Locking bolt	74	B17442	Container lid
22	B18504	Decorative door assy	75	N110461	Double ball catch
23	L02692	Hinge	76	L01446	Lock washer
24	N108427	Headless screw M05X12	77	N111459	Allen screw M03X08
25	N111964	Hexagonal screw M05X08	79	L01502	Lock washer
26	Z35960	Hinge plate	80	N111950	Hexagonal screw M05x10
27	N111973	Hexagonal nut M05	81	N108427	Headless screw M05X12
28	Z36081	Hinge stop angle	82	L02669	Hinge lid
29	L02660	Closure flap	83	L02668	Hinge stove
30	N112138	Hexagonal screw M05X12	84	L02670	Magnet holder plate
31	Z34857	Locking bolt	85	N111732	Magnetic switch top part
32	N111856	Hexagonal countersunk screw M04x12	86	N111842	Hexagon socket M03x10
33	L02219	Holder plate	87	N111733	Magnetic switch bottom part
34	L02220	Lock tongue	88	Z35691	Spring plug
35	N111965	Washer M05	89	N112136	Self-tapping screw M05X08
36	N112027	Magnet	90	N112017	Key
37	N112051	Hexagonal screw M05X25	91	B17458	Rear wall
38	N100141	Hexagonal nut M05	92	B17473	Side casing panel right back, aluminium black
39	Z36082	Magnetic bolt	93	N112490	Levelling screw black
40	N112047	Hexagon socket screw M08x35	94	B17475	Side casing right/front, left/back RAO, aluminium black
	N112207	Blind rivet nut	95	N111931	Hexagonal nut
41	N112389	Washer	96	N112009	Flat washer
42	B17424	Combustion chamber cover assy	97	B17466	Cover panel, bottom
43	Z35930	Baffle plate 2	98	B17474	Side casing panel front, aluminium black
45 *6	Z36452	Casting rear wall top black	99	B17476	Side casing panel left back AH, aluminium black
46	Z36604	Firebrick lining right		E15664	Side panel for flue pipe connection left
47	Z36579	Cast rear panel bottom black	100	Z35962	Cover panel, top
48	Z36603	Firebrick lining left	101	B18295	Cover frame AH assy
50	N112470	Spring clip	102	N111731	Container seal
51	Z36162	Fire trough	103	B18304	Convection fins
52	N107048	Sealing cord black D10	104	N112145	Hexagon socket screw M05X16
53	N112145	Hexagon socket screw M05X16	105	Z35183	Friction bearing D10
54	Z36163	Grate			
55	L02726	Small plate			

Note: Please consider the powdercoated parts can differ slightly in colour and colour effects though they are elaborated in high quality. Fairing parts with minor damage cannot be repaired and must therefore be replaced as spare parts. There is no matching RAL colour for the painted fairing parts.

Nr.	Art.Nr.	Description
106	B12301	Auger
107	Z35581	Seal
108	Z35182	Friction bearing D16
109	L00797	Motor holder plate
110	N112499	Grub screw M6x16
111	Z11915	Lock ring conveyer screw
112	N112030	Screw motor, stepless
113	B19655	Fan motor packed
114	B17370	Induced draft fan housing
115	N111604	Fuse 2,5 A
116	N112016	Power switch
117	N111989	USB cable
118	B16030	Additional motherboard for motor, incl. cable
119	N112102	Differential pressure switch
120	B16561	Mainboard USB11
121	L02678	Holding blade comb. chamber casing
122	N111892	Silicon hose
123	N111843	Washer M08
124	N109512	Hexagon socket screw M08X30
125	N100141	Hexagonal nut M05
126	L02677	Actuating cam
127	N111825	Contact switch
128	N112021	Turning grid motor
129	N112059	Allen screw M04X08
130	N111950	Hexagonal screw M05x10
131	B17166	Ceramic ignition
132 *1	B18172	Pressure Pipe
*2	B18173	Pressure Pipe
133	N111551	Silicon hose
	N112316	T-Joint
134	B16676	Flame temperatur sensor
135	B15248	Sensor tube
136	B17158	Touch-display screwable
137	L02667	Holder touch-display
138	N112031	Screw 2,5X06
139*5	L03918	Holder touch-display
149	N113219	Chipboard screw M5X30
150	N111801	Grub screw
151	B18676	Kit baffle plates 1, mount
	L03712	Mount
152	Z38211	Baffle plate 1 left
153	Z38411	Baffle plate 1 right
160	Z36922	Holder plate
162	N112387	Wing nut
163	N112551	Round sealing strip grey D11 (1m)
164	Z36923	Cleaning opening
165	N112388	Headless screw M08X25
166	N111696	Headless screw M08x30
167	B18133	Hinge
168	N105378	Hexagonal nut

Nr.	Art.Nr.	Description
169	N112390	Cylindrical pin
170	N112386	Swing bolt M08X40
171*4	Z35724	Combustion chamber cover black
172	N111937	Round sealing strip grey D12
173	N100475	Flat packing white 8x2
174	Z40075	Seal Induced draft fan
	B18996	Wiring harness
	Z35018	Cable for touch-screen 1,25 m
	Z34841	Cable for additional motherboard
	B18052	Combustion chamber kit up to serial number 1367917
*3	B17962	Pressure monitoring kit
	B18662	Set turning grid connection SUMO

Version RAO

139	Z37265	Cover frame RAO
	B18296	Cover frame RAO assy
140	B17480	Rear wall RAO
141	B17475	Side casing right/front, left/back RAO, aluminium black
142	B17455	Cover RAO
143	N112009	Flat washer
144	N105066	Hexagon socket screw M05X12
145	B17451	Container lid RAO
146	B17625	Side panel slate black right
	B18622	Side panel white right
	B17629	Side panel rust effect metallic right
	B17630	Side panel rust effect right
	B17622	Side panel glass black right
147	B17627	Side panel slate black left RAO
	B18636	Side panel white left RAO
	B17635	Side panel rust effect metallic left RAO
	B17636	Side panel rust effect left RAO
	B17624	Side panel glass black left RAO
148	B17626	Side panel slate black left
	B18623	Side panel white left
	B17632	Side panel rust effect metallic left
	B17633	Side panel rust effect left
	B17623	Side panel glass black left
149	N113219	Chipboard screw M5X30
	*1	position in the drop shaft
	*2	position in the combustion chamber from serial number 1367918
	*3	up to serial number 1366933
	*4	up to serial number 1379139 order part B17424
	*5	from serial number 201470595
	*6	Up to serial number 201470595 the Casting rear wall bottom (Z36579) must be supplied as a spare part when replacing the Casting rear wall top (Z36452).

Note: Please consider the powdercoated parts can differ slightly in colour and colour effects though they are elaborated in high quality. Fairing parts with minor damage cannot be repaired and must therefore be replaced as spare parts. There is no matching RAL colour for the painted fairing parts.

Spare parts overview Exploded view - SUMO MULTIAIR

Note

Only original parts supplied by the manufacturer may be used.

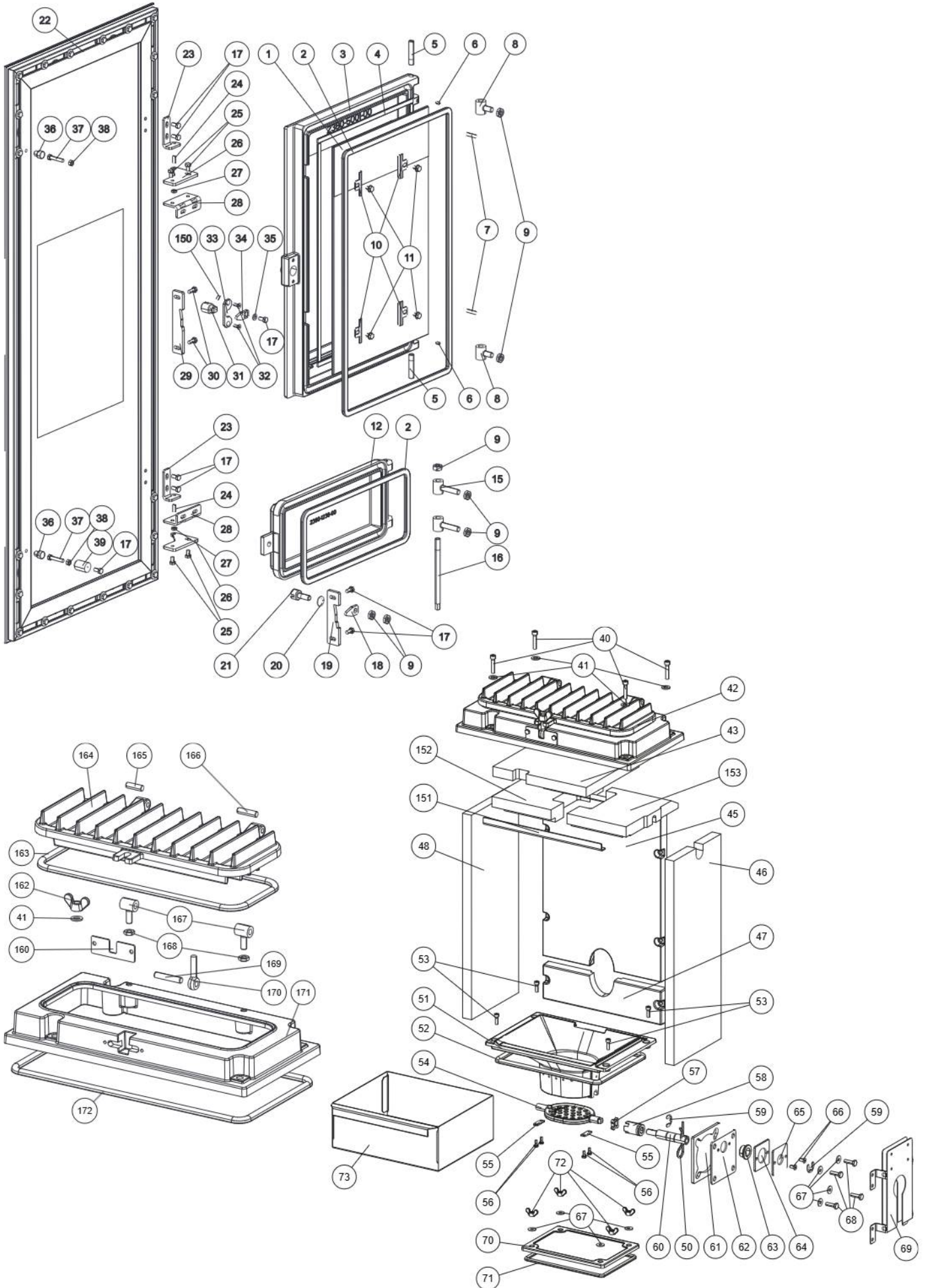

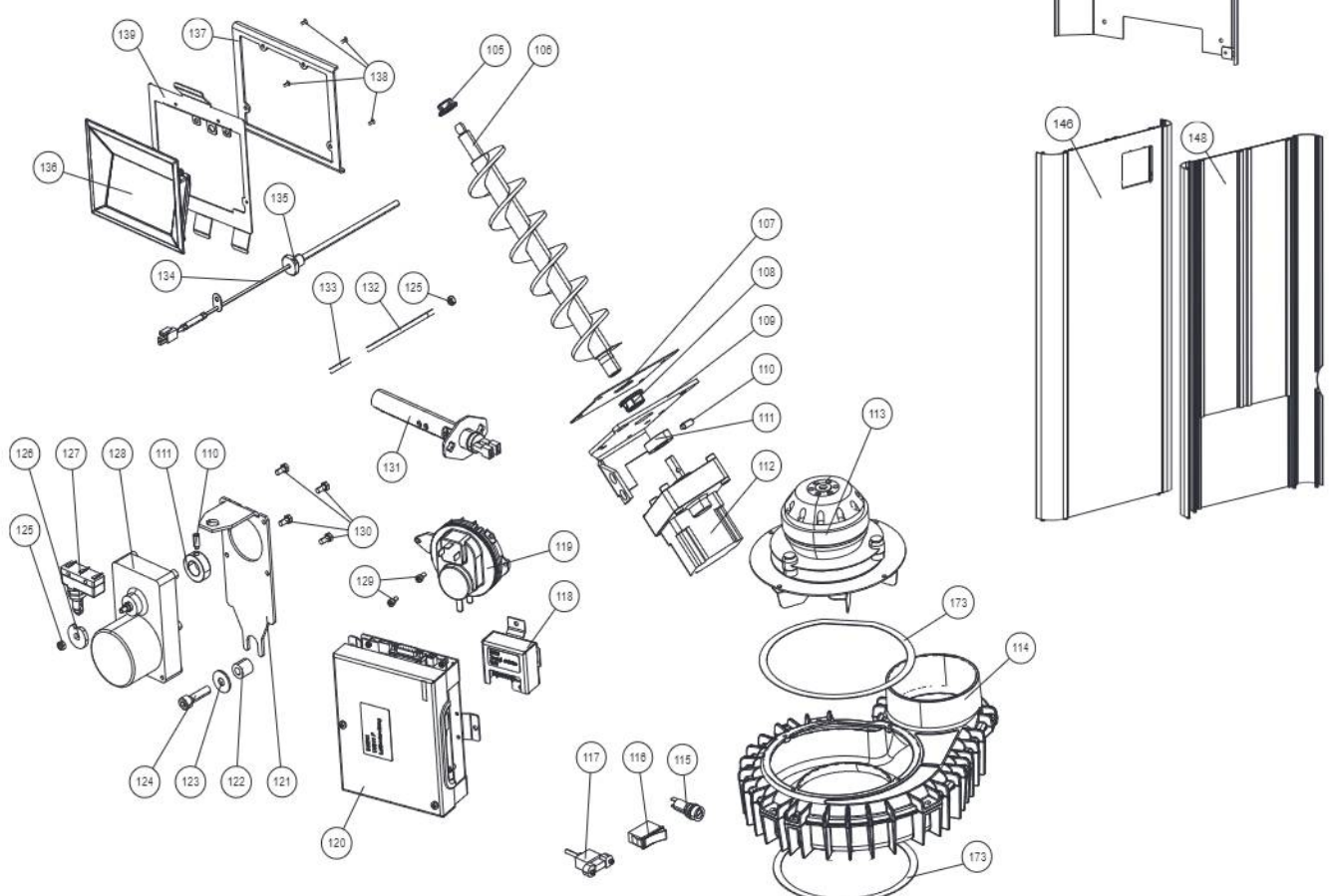
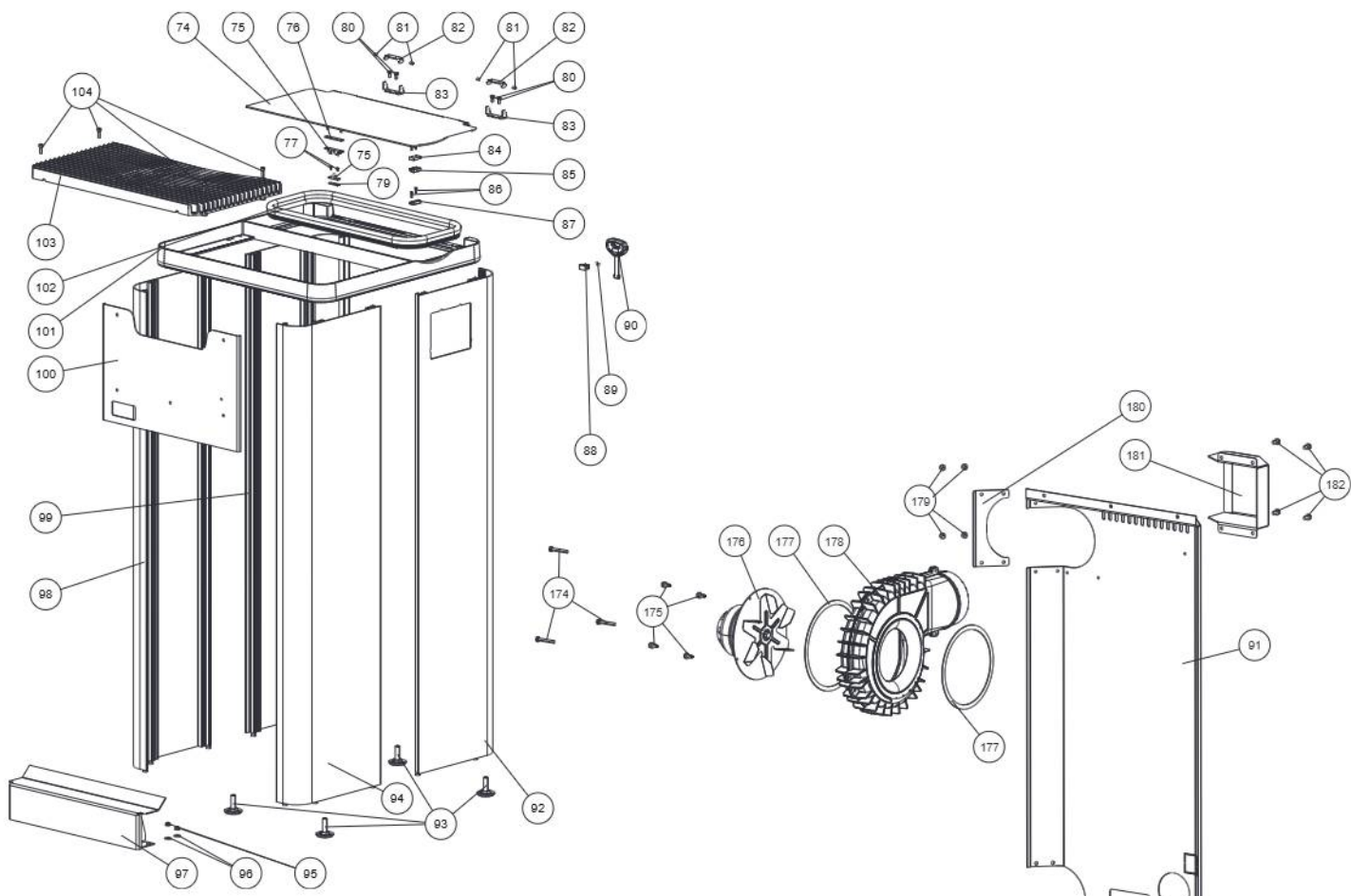

Spare part overview article numbers - SUMO MULTIAIR

Nr.	Art.Nr.	Description	Nr.	Art.Nr.	Description
1	Z37257	Front door glass	55	L02726	Small plate
2	N112551	Round sealing strip grey D11 (1m)	56	N112148	Hexagonal screw M04X10
3	Z35727	Combustion chamber door	57	L02675	Catch plate
4	N103693	Flat seal black 8x2	58	Z36165	Intermediate shaft
5	N112181	Headless screw M08X40	59	N112125	Circlips
6	N112182	Grub screw	60	Z35950	Drive shaft turning grid
7	N111637	Setscrew door opener M05X20	61	Z35951	Seal bearing
8	B17524	Hinge black	62	Z36934	Bearing holder plate
9	N105378	Hexagonal nut	63	N102688	Sinter bearing ID16
10	L00475	Glass holder	64	Z36933	Intermediary
11	N107488	Hexagonal screw M05x08	65	L02686	Holder plate
12	Z35725	Cleaning opening	66	N108485	Allen screw M05X10
15	B15396	Hinge	67	N112009	Flat washer
16	Z35923	Hinge shaft	68	N111968	Hexagonal screw M06
17	N111950	Hexagonal screw M05x10	69	LB00625	Heat protection assy
18	L02713	Fastener tongue	70	Z35451	Cleaning opening
19	L02712	Closure flap	71	N103066	Round sealing strip black D06
20	N100699	Disc spring	72	N112077	Wing nut
21	Z35924	Locking bolt	73	L02659	Ash drawer
22	B18504	Decorative door assy	74	B17442	Container lid
23	L02692	Hinge	75	N110461	Double ball catch
24	N108427	Headless screw M05X12	76	L01446	Lock washer
25	N111964	Hexagonal screw M05X08	77	N111459	Allen screw M03X08
26	Z35960	Hinge plate	79	L01502	Lock washer
27	N111973	Hexagonal nut M05	80	N111950	Hexagonal screw M05x10
28	Z36081	Hinge stop angle	81	N108427	Headless screw M05X12
29	L02660	Closure flap	82	L02669	Hinge lid
30	N112138	Hexagonal screw M05X12	83	L02668	Hinge stove
31	Z34857	Locking bolt	84	L02670	Magnet holder plate
32	N111856	Hexagonal countersunk screw M04x12	85	N111732	Magnetic switch top part
33	L02219	Holder plate	86	N111842	Hexagon socket M03x10
34	L02220	Lock tongue	87	N111733	Magnetic switch bottom part
35	N111965	Washer M05	88	Z35691	Spring plug
36	N112027	Magnet	89	N112136	Self-tapping screw M05X08
37	N112051	Hexagonal screw M05X25	90	N112017	Key
38	N100141	Hexagonal nut M05	91	LB00904	Rear wall MA
39	Z36082	Magnetic bolt	92	B17473	Side casing panel right back, aluminium black
40	N112047	Hexagon socket screw M08x35	93	N112490	Levelling screw black
	N112207	Blind rivet nut	94	B17475	Side casing right/front, left/back RAO, aluminium black
41	N112389	Washer	95	N111931	Hexagonal nut
42	B17424	Combustion chamber cover assy	96	N112009	Flat washer
43	Z35930	Baffle plate 2	97	B17466	Cover panel, bottom
45 *4	Z36452	Casting rear wall top black	98	B17474	Side casing panel front, aluminium black
46	Z36604	Firebrick lining right	99	B17476	Side casing panel left back AH, aluminium black
47	Z36579	Cast rear panel bottom black		E15664	Side panel for flue pipe connection left
48	Z36603	Firebrick lining left	100	Z35962	Cover panel, top
50	N112470	Spring clip	101	Z35977	Convection cover RAO
51	Z36162	Fire trough		B17537	Cover frame RAO assy
52	N107048	Sealing cord black D10	102	N111731	Container seal
53	N112145	Hexagon socket screw M05X16	103	B18304	Convection fins
54	Z36163	Grate			

Note: Please consider the powdercoated parts can differ slightly in colour and colour effects though they are elaborated in high quality. Fairing parts with minor damage cannot be repaired and must therefore be replaced as spare parts. There is no matching RAL colour for the painted fairing parts.

Nr.	Art.Nr.	Description
104	N112145	Hexagon socket screw M05X16
105	Z35183	Friction bearing D10
106	B12301	Auger
107	Z35581	Seal
108	Z35182	Friction bearing D16
109	L00797	Motor holder plate
110	N112499	Grub screw M6x16
111	Z11915	Lock ring conveyer screw
112	N112030	Screw motor, stepless
113	B19655	Fan motor packed
114	B17370	Induced draft fan housing
115	N111604	Fuse 2,5 A
116	N112016	Power switch
117	N111989	USB cable
118	B16030	Additional motherboard for motor, incl. cable
119	N112102	Differential pressure switch
120	B16561	Mainboard USB11
121	L02678	Holding blade comb. chamber casing
122	N111892	Silicon hose
123	N111843	Washer M08
124	N109512	Hexagon socket screw M08X30
125	N100141	Hexagonal nut M05
126	L02677	Actuating cam
127	N111825	Contact switch
128	N112021	Turning grid motor
129	N112059	Allen screw M04X08
130	N111950	Hexagonal screw M05x10
131	B17166	Ceramic ignition
132 *1	B18172	Pressure Pipe
*2	B18173	Pressure Pipe
133	N111551	Silicon hose
	N112316	T-Joint
134	B16676	Flame temperatur sensor
135	B15248	Sensor tube
136	B17158	Touch-display screwable
137	L02667	Holder touch-display
138	N112031	Screw 2,5X06
139*3	L03918	Holder touch-display
146	B17625	Side panel slate black right
	B18622	Side panel white right
	B17629	Side panel rust effect metallic right
	B17630	Side panel rust effect right
	B17622	Side panel glass black right
148	B17626	Side panel slate black left
	B18623	Side panel white left
	B17632	Side panel rust effect metallic left
	B17633	Side panel rust effect left
	B17623	Side panel glass black left
149	N113219	Chipboard screw M5X30
150	N111801	Grub screw
151	B18676	Kit baffle plates 1, mount
	L03712	Mount

Nr.	Art.Nr.	Description
152	Z38211	Baffle plate 1 left
153	Z38411	Baffle plate 1 right
160	Z36922	Holder plate
162	N112387	Wing nut
163	N112551	Round sealing strip grey D11 (1m)
164	Z36923	Cleaning opening
165	N112388	Headless screw M08X25
166	N111696	Headless screw M08x30
167	B18133	Hinge
168	N105378	Hexagonal nut
169	N112390	Cylindrical pin
170	N112386	Swing bolt M08X40
171	Z35724	Combustion chamber cover black
172	N111937	Round sealing strip grey D12
173	N100475	Flat packing white 8x2
174	N111806	Hexagonal screw M05X35
175	N106989	Hexagonal screw
176	B19656	Fan motor MULTIAIR packed
	B17101	Convection fan assy
177	N100475	Flat packing white 8x2
178	B16155	Induced draft fan housing
179	N111911	Self-tapping screw M05X08
180	L03903	Covering plate
181	L03904	Motor protection cover
182	N112240	Self-tapping screw M05x10
	E15900	Sealing kit FILO / SUMO
	B18996	Wiring harness
	Z35018	Cable for touch-screen 1,25 m
	Z34841	Cable for additional motherboard
	B18662	Set turning grid connection SUMO
	*1	position in the drop shaft
	*2	position in the combustion chamber
	*3	from serial number 201470595
	*4	Up to serial number 201470595 the Casting rear wall bottom (Z36579) must be supplied as a spare part when replacing the Casting rear wall top (Z36452).

Note: Please consider the powdercoated parts can differ slightly in colour and colour effects though they are elaborated in high quality. Fairing parts with minor damage cannot be repaired and must therefore be replaced as spare parts. There is no matching RAL colour for the painted fairing parts.

13. GUARANTEE CONDITIONS

We recommend having the installation performed by a RIKA-certified technician.

These guarantee conditions only apply for the European mainland. For all other countries, the separate conditions of the importer in the respective country apply. In cases of doubt, or in the case of missing or incorrect translations, the German version is always the sole valid version.

In the interest of ensuring damage limitation in good time, the guarantee claim should be sent in writing to the RIKA specialist or contract dealer.

In this event, the following documents must be presented:

- Written reason for complaint
- Invoice
- Commissioning record
- Model name and serial number

RIKA GUARANTEE

5 YEARS

on the welded stove body.

Up to 5 years or 10,000 kg of consumed pellets for pellet stoves.

The RIKA guarantee is a commercial or manufacturer's guarantee (subject to certain exceptions).

This relates exclusively to defects in the material and processing, and to the supply of replacement parts free of charge. Working hours and travel times are not covered by the manufacturer's guarantee.

The guarantee is conditional on the following:

- Only original parts supplied by the manufacturer must be used.
- Professional installation of the stove in compliance with the respective operating manual valid at the time of purchase.
- The stove must be connected by a professional certified for that type of stove.
- The commissioning is performed by a RIKA-certified technician.

If these points are not complied with, the guarantee claim is void!

Any costs incurred by the manufacturer as a result of an unjustified guarantee claim will be charged back to the claimant. Likewise excluded from the guarantee is any damage resulting from or caused by non-compliance with the manufacturer's instructions for operating the appliance, e.g. overheating, use of non-approved fuels, unprofessional interference with the appliance or the flue pipe, a flue suction that is incorrectly adjusted to the appliance or is insufficient or too strong, condensation water, non-performance of or inadequate maintenance or cleaning, non-compliance with the applicable building regulations, improper operation by the operator or third parties, transport and handling damage.

STATUTORY WARRANTY PROVISIONS REMAIN UNAFFECTED BY THE GUARANTEE!

14. WARRANTY CONDITIONS

As a consumer, you are entitled to the warranty, which covers any defects at the time of delivery. The warranty is two (2) years from the date of delivery of the stove.

See the respective general terms and conditions of business and warranty conditions of the RIKA dealer.

The warranty does not cover:

1. Wearing parts (normal wear and tear not resulting from a defect)
2. Parts in contact with fire, e.g. glass, combustion troughs, grates, baffle plates, deflectors, combustion chamber cladding (e.g. refractory clay), ceramics, ignition elements, sensors, combustion chamber sensors and temperature monitors
3. Paint, surface coatings (e.g. handles, cover panels)
4. Seals
5. Natural stone, thermal stone, etc.

valid from: 01.07.2023

15. DISPOSAL INFORMATION

RIKA Innovative Ofentechnik GmbH is ensuring that its products are eco-friendly throughout the product life cycle. This is why our commitment for electronic products goes beyond the end of their product life cycle.

Note

For proper disposal of the device, we recommend contacting a local waste disposal company.

Note

Please contact your RIKA specialist dealer for professional disassembly/dismantling of the device.

Note

We recommend that you remove the parts that come into contact with the fire, such as glass, fire trough, grates, draught plates, baffle plates, combustion chamber linings (e.g. fireclay), ceramics, ignition elements, sensors, combustion chamber sensors and temperature monitors and dispose of them in the household waste.

Information on the individual components of the device

- **Electrical or electronic components:** Remove the electrical or electronic components from the device by disassembling them. These components must not be disposed of in the residual waste. Proper disposal should be carried out via the waste electrical equipment take-back system.
- **Fireclay in the combustion chamber:** Remove fireclay components that have been installed in the combustion chamber from the appliance. If present, fastening elements must be removed beforehand. Fireclay components that come into contact with the fire or flue gas must be disposed of; reuse or recycling is not possible.
- **Vermiculite in the combustion chamber:** Remove vermiculite that has been installed in the combustion chamber from the appliance. If present, fastening elements must be removed beforehand. Vermiculite in contact with fire or flue gas must be disposed of, reuse or recycling is not possible.
- **Glass ceramic pane:** Remove the glass ceramic pane using a suitable tool. Remove the seals and separate them from the frame if present. Transparent glass ceramic can generally be recycled, but must be separated into decorated and non-decorated panes. The glass ceramic pane can be disposed of as construction waste.
- **Sheet steel:** Disassemble the sheet steel components of the device by unscrewing or flexing (alternatively by mechanical crushing). If present, remove the seals beforehand. Dispose of the sheet steel parts as metal scrap.
- **Cast iron:** Disassemble the components of the cast iron device by unscrewing or flexing (alternatively by mechanical crushing). If present, remove gaskets beforehand. Dispose of the cast parts as metal scrap.
- **Natural stone:** Remove existing natural stone mechanically from the unit and dispose of as construction waste.
- **Gaskets (glass fibre):** Remove the gaskets mechanically from the device. These components must not be disposed of with residual waste, as waste glass fibre cannot be destroyed by incineration. Dispose of gaskets as glass and ceramic fibres (artificial mineral fibres).
- **Metal handles and decorative elements:** If present, remove or dismantle metal handles and decorative elements and dispose of them as metal scrap.

Note

Please observe the local disposal possibilities for all components.

Extract from the waste code of the European Waste List Regulation

Waste code	Waste type
15 01 03	Wooden packaging
17 01 03	Tiles and ceramics
17 02 02	Glass
17 04 05	Iron and steel
17 05 04	Soil and stones

ENGLISH

Electronic Waste

In accordance with the European Directive (2012/19/EU) Waste Electrical and Electronic Equipment (WEEE) and other local regulations, RIKA supports the setup of take-back systems and recycling infrastructures.

Old devices can easily be returned to the municipal waste collectors for recycling purposes. Please observe the national regulations to that end.



The device may not be disposed of in the normal household waste.

16. COMPLIANCE WITH EU REGULATIONS



This product complies with the requirements of the European Community.

Hereby, RIKA Innovative Ofentechnik GmbH declares that this device is in compliance with the essential requirements and other relevant provisions of Directive 2014/30/EU, 2014/35/EU, 2014/65/EU and 2011/1185/EU.

The most recent and valid version of the DoC (Declaration of Conformity) can be viewed at www.rika.at



RIKA Innovative Ofentechnik GmbH

Müllerviertel 20

4563 Micheldorf / AUSTRIA

Tel.: +43 (0)7582/686 - 41, Fax: -43

verkauf@rika.at

www.rika.at

In case of doubt as well as missing or incorrect translations, the German version is the only valid one. Subject to technical and visual changes as well as layout and printing errors.

© 2026 | RIKA Innovative Ofentechnik GmbH